

COLLECTIONS

AGOPROFIL[®]

P O R T E  P E N S A T E

AGOPROFIL®
PORTE  PENSATE



INTRO

Benvenuti nel catalogo completo della nostra azienda, dove l'innovazione, la qualità e l'eccellenza si incontrano per offrire soluzioni straordinarie per le vostre esigenze.

Welcome to our comprehensive catalog, where innovation, quality, and excellence come together to offer extraordinary solutions for your needs.

Bienvenue dans notre catalogue complet, où l'innovation, la qualité et l'excellence se rejoignent pour offrir des solutions extraordinaires à vos besoins.



Mission

MISSION
MISSION

La nostra missione è creare porte per interni che non solo soddisfino le esigenze pratiche dei nostri clienti, ma che trasformino gli spazi abitativi in luoghi di bellezza e funzionalità senza compromessi.

Siamo qui per trasformare le vostre visioni in realtà e per rendere ogni ambiente un luogo accogliente, funzionale e bello da vivere. Ci impegniamo a offrire prodotti di alta qualità, realizzati con materiali durevoli e tecnologie innovative, che rispecchiano la nostra dedizione alla precisione artigianale e al design elegante.

Le nostre porte non sono solo elementi funzionali di una casa, ma veri e propri elementi di stile che aggiungono valore estetico e carattere a qualsiasi ambiente.

Our mission is to create interior doors that not only meet the practical needs of our customers but also transform living spaces into places of beauty and functionality without compromise.

We are here to turn your visions into reality and to make every environment a welcoming, functional, and beautiful place to live. We are committed to offering high-quality products, made with durable materials and innovative technologies, reflecting our dedication to craftsmanship and elegant design.

Our doors are not just functional elements of a home, but true style statements that add aesthetic value and character to any space.

Notre mission est de créer des portes intérieures qui répondent non seulement aux besoins pratiques de nos clients, mais qui transforment également les espaces de vie en lieux de beauté et de fonctionnalité sans compromis.

Nous sommes là pour concrétiser vos visions et pour faire de chaque environnement un endroit accueillant, fonctionnel et agréable à vivre. Nous nous engageons à offrir des produits de haute qualité, fabriqués avec des matériaux durables et des technologies innovantes, qui reflètent notre dévouement à l'artisanat précis et au design élégant.

Nos portes ne sont pas seulement des éléments fonctionnels d'une maison, mais de véritables éléments de style qui ajoutent de la valeur esthétique et du caractère à n'importe quel espace.

Identità

IDENTITY
IDENTITÉ



Siamo costantemente impegnati nella ricerca della nostra identità e nell'offrire ai nostri clienti una garanzia di qualità e autenticità. È per questo che abbiamo introdotto la nostra esclusiva targhetta di riconoscimento, un simbolo di eccellenza e impegno verso l'eccellenza.

Ogni prodotto che porta il nostro marchio di riconoscimento è stato attentamente selezionato e sottoposto a rigorosi controlli di qualità per garantire la massima soddisfazione del cliente. Questo marchio distintivo rappresenta il nostro impegno per la perfezione e la nostra dedizione a offrire prodotti di altissima qualità.

In un mercato affollato e competitivo, il nostro logo di riconoscimento è il nostro modo di distinguerci e di confermare il nostro impegno per l'eccellenza in tutto ciò che facciamo. Siamo orgogliosi di presentare questo simbolo ai nostri clienti e di offrire loro la tranquillità che deriva dal sapere di avere scelto il meglio. Scegliere un prodotto contrassegnato con il nostro marchio di riconoscimento non è solo una scelta di qualità, ma anche una dichiarazione di fiducia nella nostra identità e nel nostro impegno per l'eccellenza. Grazie per aver scelto AGOPROFIL dove la qualità e l'identità si incontrano.

We are constantly committed to finding our identity and providing our customers with a guarantee of quality and authenticity. That's why we introduced our exclusive recognition label, a symbol of excellence and commitment to perfection.

Every product bearing our recognition label has been carefully selected and subjected to rigorous quality controls to ensure maximum customer satisfaction.

This distinctive mark represents our commitment to perfection and dedication to offering high-quality products. In a crowded and competitive market, our recognition logo is our way of distinguishing ourselves and confirming our commitment to excellence in everything we do. We are proud to present this symbol to our customers and offer them the peace of mind that comes from knowing they have chosen the best.

Choosing a product marked with our recognition label is not only a choice of quality but also a statement of trust in our identity and commitment to excellence. Thank you for choosing AGOPROFIL where quality and identity meet.

Nous sommes constamment engagés dans la recherche de notre identité et dans l'offre à nos clients d'une garantie de qualité et d'authenticité. C'est pourquoi nous avons introduit notre étiquette de reconnaissance exclusive, un symbole d'excellence et d'engagement envers la perfection.

Chaque produit portant notre étiquette de reconnaissance a été soigneusement sélectionné et soumis à des contrôles de qualité rigoureux pour garantir la satisfaction maximale du client. Ce signe distinctif représente notre engagement envers la perfection et notre dévouement à offrir des produits de très haute qualité.

Dans un marché encombré et compétitif, notre logo de reconnaissance est notre façon de nous distinguer et de confirmer notre engagement envers l'excellence dans tout ce que nous faisons. Nous sommes fiers de présenter ce symbole à nos clients et de leur offrir la tranquillité d'esprit qui vient du fait de savoir qu'ils ont choisi le meilleur. Choisir un produit marqué de notre logo de reconnaissance n'est pas seulement un choix de qualité, mais aussi une déclaration de confiance en notre identité et en notre engagement envers l'excellence. Merci d'avoir choisi AGOPROFIL où la qualité et l'identité se rencontrent.



L'azienda

THE COMPANY
L'ENTREPRISE

Da oltre 52 anni, siamo impegnati a fornire prodotti e servizi di alto livello per soddisfare le esigenze dei nostri clienti in vari settori. Il nostro catalogo offre una vasta gamma di porte e sistemi, dai più avanzati dispositivi tecnologici alle soluzioni su misura per l'ambiente domestico e industriale. Siamo orgogliosi di collaborare con i migliori fornitori per garantire la massima qualità e affidabilità dei nostri prodotti.

Siamo consapevoli dell'importanza dell'innovazione e dell'adattamento alle mutevoli esigenze del mercato. **Perciò, investiamo costantemente in ricerca e sviluppo per offrire soluzioni all'avanguardia che migliorino la vita dei nostri clienti e contribuiscano al loro successo.** Oltre alla nostra dedizione alla qualità e all'innovazione, ci impegniamo anche per l'eccellenza nel servizio clienti. Siamo qui per supportarvi in ogni fase, dal momento dell'acquisto fino alla consegna e oltre. La vostra soddisfazione è la nostra priorità assoluta. Esplorate il nostro catalogo e scoprite come possiamo aiutarvi a raggiungere i vostri obiettivi. Siamo entusiasti di collaborare con voi e di offrirvi le migliori soluzioni per le vostre esigenze. Grazie per la fiducia che ci dimostrate scegliendo i nostri prodotti e servizi.

For over 52 years, we have been committed to providing high-level products and services to meet the needs of our customers in various sectors.

Our catalog offers a wide range of products, from cutting-edge technological devices to tailor-made solutions for both domestic and industrial environments. We take pride in collaborating with top suppliers to ensure the highest quality and reliability of our products.

We understand the importance of innovation and adapting to the ever-changing market needs.

Therefore, we continually invest in research and development to offer cutting-edge solutions that enhance our customers' lives and contribute to their success.

In addition to our dedication to quality and innovation, we also strive for excellence in customer service. We are here to support you at every stage, from purchase to delivery and beyond. Your satisfaction is our top priority.

Explore our catalog and discover how we can help you achieve your goals. We are excited to collaborate with you and provide you with the best solutions for your needs. Thank you for choosing our products and services and for the trust you place in us.

Depuis plus de 52 années, nous nous engageons à fournir des produits et des services de haut niveau pour répondre aux besoins de nos clients dans divers secteurs.

Notre catalogue propose une large gamme de produits, des appareils technologiques de pointe aux solutions sur mesure pour les environnements domestiques et industriels. Nous sommes fiers de collaborer avec les meilleurs fournisseurs pour garantir la plus haute qualité et fiabilité de nos produits.

Nous comprenons l'importance de l'innovation et de l'adaptation aux besoins du marché en constante évolution.

C'est pourquoi nous investissons continuellement dans la recherche et le développement pour offrir des solutions de pointe qui améliorent la vie de nos clients et contribuent à leur réussite.

En plus de notre dévouement à la qualité et à l'innovation, nous visons également l'excellence en matière de service client. Nous sommes là pour vous soutenir à chaque étape, de l'achat à la livraison et au-delà. Votre satisfaction est notre priorité absolue. Explorez notre catalogue et découvrez comment nous pouvons vous aider à atteindre vos objectifs.

Nous sommes ravis de collaborer avec vous et de vous fournir les meilleures solutions pour vos besoins. Merci d'avoir choisi nos produits et services et pour la confiance que vous nous accordez.

Certificazioni

CERTIFICATIONS
CERTIFICATION

La nostra dedizione alla qualità e all'eccellenza è testimoniata da una serie di prestigiose certificazioni. Siamo orgogliosi di aver ottenuto riconoscimenti che confermano il nostro impegno per standard elevati e pratiche aziendali sostenibili. Tra le nostre certificazioni più significative figurano:

•**DNV ISO 9001:2000: CERTIFICAZIONE** Standard internazionale per la gestione della qualità, che attesta la nostra capacità di fornire prodotti e servizi che soddisfano le esigenze e le aspettative dei nostri clienti in modo coerente.

•**LAPI EI 30 CERTIFICAZIONE** La certificazione EI30 è richiesta per porte, finestre, partizioni e altri elementi strutturali che separano gli ambienti all'interno di un edificio. È importante notare che il valore "EI" è una classificazione europea che indica la resistenza al fuoco secondo tre criteri: **E (Integrità)**: indica la capacità di un elemento di mantenere la sua integrità strutturale durante l'esposizione al fuoco. **I (Isolamento termico)**: indica la capacità di un elemento di limitare la trasmissione del calore attraverso di esso durante l'esposizione al fuoco. **Numerico**: indica il tempo, in minuti, per il quale l'elemento soddisfa i requisiti di integrità e isolamento termico.

•**LAPI EI 60 CERTIFICAZIONE** La certificazione EI 60 è richiesta per porte, finestre, partizioni e altri elementi strutturali che separano gli ambienti all'interno di un edificio. È importante notare che il valore "EI" è una classificazione europea che indica la resistenza al fuoco secondo tre criteri: **E (Integrità)**: indica la capacità di un elemento di mantenere la sua integrità strutturale durante l'esposizione al fuoco. **I (Isolamento termico)**: indica la capacità di un elemento di limitare la trasmissione del calore attraverso di esso durante l'esposizione al fuoco. **Numerico**: indica il tempo, in minuti, per il quale l'elemento soddisfa i requisiti di integrità e isolamento termico.

•**ISTITUTO GIORDANO CERTIFICAZIONE** tenuta fumi è un documento che attesta che un sistema o un dispositivo progettato per prevenire la diffusione del fumo da un ambiente all'altro ha superato i test di conformità e soddisfa determinati standard di sicurezza.

•**LAPI CERTIFICAZIONE ACUSTICA 31DB** La certificazione acustica 31 dB si riferisce alla capacità di un materiale o di una struttura di fornire un'attenuazione del rumore di 31 decibel (dB) in determinate condizioni di test. Questa certificazione viene spesso utilizzata nel settore delle costruzioni e dell'edilizia per valutare le prestazioni acustiche di pareti, finestre, porte o altri componenti che separano gli ambienti.

•**LAPI CERTIFICAZIONE ACUSTICA 39DB** La certificazione acustica 39 dB si riferisce alla capacità di un materiale o di una struttura di fornire un'attenuazione del rumore di 39 decibel (dB) in determinate condizioni di test. Questa certificazione viene spesso utilizzata nel settore delle costruzioni e dell'edilizia per valutare le prestazioni acustiche di pareti, finestre, porte o altri componenti che separano gli ambienti.

Queste certificazioni sono il risultato del nostro impegno costante per l'eccellenza e riflettono i nostri valori fondamentali di qualità, responsabilità e sostenibilità. Siamo determinati a continuare su questa strada, cercando costantemente di migliorare e di soddisfare sempre più rigorosi standard di qualità e sostenibilità.

DNV ISO 9001:2000: Certificazioni



EI30 Certification



EI60 Certification



Istituto Giordano Certification

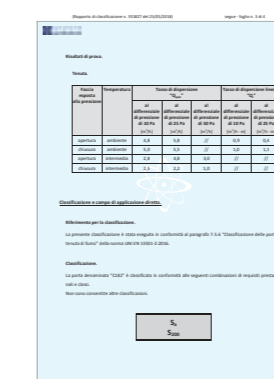
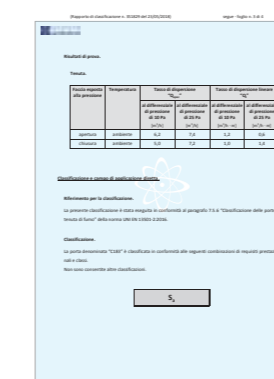

31DB Certificazioni

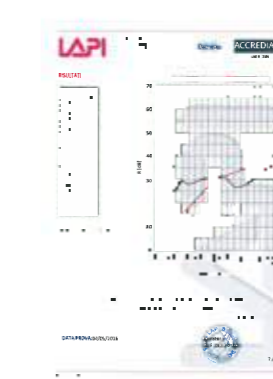

39DB Certificazioni

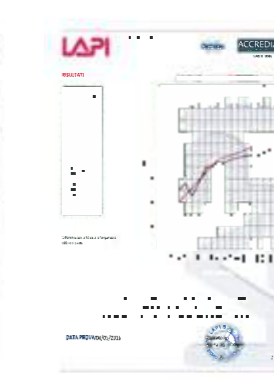

Certificazioni

CERTIFICATIONS
CERTIFICATION

Our dedication to quality and excellence is evidenced by a series of prestigious certifications. We are proud to have achieved recognition that confirms our commitment to high standards and sustainable business practices. Among our most significant certifications are:

- **DNV ISO 9001:2000 Certification:** An international standard for quality management, attesting to our ability to provide products and services that consistently meet the needs and expectations of our customers.
- **LAPI EI 30 Certification:** This certification is required for doors, windows, partitions, and other structural elements separating spaces within a building. The "EI" value is a European classification indicating fire resistance based on three criteria: Integrity, Thermal insulation, and Numerical value representing the duration in minutes for which the element meets integrity and thermal insulation requirements.
- **LAPI EI 60 Certification:** This certification is required for doors, windows, partitions, and other structural elements separating spaces within a building. The "EI" value is a European classification indicating fire resistance based on three criteria: Integrity, Thermal insulation, and Numerical value representing the duration in minutes for which the element meets integrity and thermal insulation requirements.
- **Istituto Giordano Smoke Seal Certification:** Attests that a system or device designed to prevent smoke diffusion between environments has passed conformity tests and meets certain safety standards.
- **LAPI Acoustic Certification 31dB:** Refers to the ability of a material or structure to provide a noise attenuation of 31 decibels (dB) under specific test conditions, commonly used in construction to evaluate the acoustic performance of walls, windows, doors, or other components separating spaces.
- **LAPI Acoustic Certification 39dB:** Similar to the above, but with a higher noise attenuation requirement, achieving 39 decibels (dB) reduction.

These certifications are the result of our constant commitment to excellence and reflect our core values of quality, responsibility, and sustainability. We are determined to continue on this path, constantly seeking improvement and striving to meet increasingly rigorous standards of quality and sustainability.

Notre dévouement à la qualité et à l'excellence est attesté par une série de prestigieuses certifications. Nous sommes fiers d'avoir obtenu des reconnaissances qui confirment notre engagement envers des normes élevées et des pratiques commerciales durables. Parmi nos certifications les plus significatives figurent:

- **Certification DNV ISO 9001:2000:** Norme internationale pour la gestion de la qualité, attestant notre capacité à fournir des produits et services répondant de manière cohérente aux besoins et aux attentes de nos clients.
- **Certification LAPI EI 30:** Cette certification est requise pour les portes, fenêtres, cloisons et autres éléments structurels séparant les espaces à l'intérieur d'un bâtiment. Il est important de noter que la valeur "EI" est une classification européenne indiquant la résistance au feu selon trois critères: Intégrité, Isolation thermique et Valeur numérique représentant la durée en minutes pendant laquelle l'élément répond aux exigences d'intégrité et d'isolation thermique.
- **Certification LAPI EI 60:** Cette certification est requise pour les portes, fenêtres, cloisons et autres éléments structurels séparant les espaces à l'intérieur d'un bâtiment. Il est important de noter que la valeur "EI" est une classification européenne indiquant la résistance au feu selon trois critères: Intégrité, Isolation thermique et Valeur numérique représentant la durée en minutes pendant laquelle l'élément répond aux exigences d'intégrité et d'isolation thermique.



- **Certification de l'Institut Giordano pour l'étanchéité aux fumées:** Atteste qu'un système ou un dispositif conçu pour prévenir la diffusion de la fumée d'un environnement à l'autre a réussi les tests de conformité et répond à certaines normes de sécurité.
- **Certification acoustique LAPI 31 dB:** Référence à la capacité d'un matériau ou d'une structure à fournir une atténuation sonore de 31 décibels (dB) dans des conditions de test spécifiques, couramment utilisée dans la construction pour évaluer les performances acoustiques des murs, fenêtres, portes ou autres composants séparant les espaces.
- **Certification acoustique LAPI 39 dB:** Similaire à celle ci-dessus, mais avec une exigence d'atténuation sonore plus élevée, de 39 décibels (dB).

Ces certifications sont le résultat de notre engagement constant envers l'excellence et reflètent nos valeurs fondamentales de qualité, de responsabilité et de durabilité. Nous sommes déterminés à poursuivre dans cette voie, cherchant constamment à nous améliorer et à répondre à des normes de qualité et de durabilité de plus en plus rigoureuses.

GREEN Concept

GREEN CONCEPT
GREEN CONCEPT

La nostra green attitude è al centro di tutto ciò che facciamo. Siamo profondamente impegnati a proteggere e preservare l'ambiente, e questo impegno si riflette in ogni aspetto della nostra attività. Ci impegniamo a ridurre al minimo l'impatto ambientale dei nostri prodotti e delle nostre operazioni. Utilizziamo materiali sostenibili e tecnologie eco-friendly in ogni fase del nostro processo produttivo, dal design alla fabbricazione, alla distribuzione e oltre.

Ci sforziamo di adottare pratiche che minimizzano il consumo di risorse naturali e riducono le emissioni di carbonio. Coniugare il livello estetico del prodotto con l'attenzione alla salute dell'utilizzatore e dell'ambiente, è la strategia che da anni **AGOPROFIL®** continua a tracciare per il proprio sviluppo produttivo. Utilizzando **vernici all'acqua**, ad alte prestazioni tali da permettere elevati standard qualitativi con livelli bassissimi di emissione di formaldeide, concretizziamo la nostra propensione e il nostro impegno per l'ambiente e la salute realizzando porte nel pieno rispetto del Pianeta.

Il nostro **GREEN concept** e la nostra costante ricerca evolutiva, ci hanno indirizzati nella scelta dell'utilizzo di materiali provenienti da foreste gestite in forma responsabile con il risultato di porte create a basso impatto ambientale e nel pieno rispetto del Pianeta senza mai perdere di vista il design e l'alta qualità che contraddistinguono il nostro operato. L'impianto di **riscaldamento** alimentato a **biomasse** e l'utilizzo del **fotovoltaico**, assicurano un'alta resa con una ridotta dispersione di anidride carbonica nell'ecosistema e l'auto produzione di energia. Contemporaneamente l'azienda attua un'**attenta raccolta differenziata**, con operazioni di **recupero pari all'90%** del totale dei rifiuti prodotti.

Siamo orgogliosi della nostra green attitude e continueremo a lavorare duramente per ridurre il nostro impatto ambientale e promuovere un futuro più sostenibile per tutti.



Our green attitude is at the heart of everything we do. We are deeply committed to protecting and preserving the environment, and this commitment is reflected in every aspect of our business.

We strive to minimize the environmental impact of our products and operations. We use sustainable materials and eco-friendly technologies at every stage of our production process, from design to manufacturing, distribution, and beyond. We endeavor to adopt practices that minimize the consumption of natural resources and reduce carbon emissions.

Blending the aesthetic level of the product with attention to the user's health and the environment is the strategy that **AGOPROFIL®** has been pursuing for years in its production development. By using **water-based paints**, high-performance enough to allow high quality standards with very low levels of formaldehyde emissions, we materialize our propensity and commitment to the environment and health by creating doors in full respect of the Planet.

Our **GREEN concept** and our constant evolutionary research have guided us in choosing to use materials from responsibly managed forests, resulting in doors with low environmental impact and in full respect of the Planet, without ever losing sight of the design and high quality that characterize our work.

The **biomass-powered heating system** and the use of **photovoltaics** ensure high efficiency with reduced carbon dioxide dispersion into the ecosystem and self-production of energy. At the same time, the company implements **careful waste sorting**, with **recovery operations accounting for 90%** of the total waste produced.

We are proud of our green attitude and will continue to work hard to reduce our environmental impact and promote a more sustainable future for all.

Notre green attitude est au cœur de tout ce que nous faisons. Nous sommes profondément engagés dans la protection et la préservation de l'environnement, et cet engagement se reflète dans tous les aspects de notre activité.

Nous nous efforçons de minimiser l'impact environnemental de nos produits et de nos opérations. Nous utilisons des matériaux durables et des technologies respectueuses de l'environnement à chaque étape de notre processus de production, du design à la fabrication, en passant par la distribution et au-delà. Nous nous efforçons d'adopter des pratiques qui minimisent la consommation de ressources naturelles et réduisent les émissions de carbone.

Conjuguer le niveau esthétique du produit avec l'attention portée à la santé de l'utilisateur et à l'environnement est la stratégie que **AGOPROFIL®** poursuit depuis des années dans le développement de sa production. En utilisant des **peintures à base d'eau**, assez performantes pour permettre des normes de qualité élevées avec des niveaux très faibles d'émissions de formaldéhyde, nous concrétisons notre propension et notre engagement envers l'environnement et la santé en créant des portes dans le respect total de la Planète.

Notre **concept GREEN** et notre recherche évolutive constante nous ont orientés vers l'utilisation de matériaux provenant de forêts gérées de manière responsable, ce qui se traduit par des portes à faible impact environnemental et dans le respect total de la Planète, sans jamais perdre de vue le design et la haute qualité qui caractérisent notre travail.

Le système de chauffage alimenté à la biomasse et l'utilisation du **photovoltaïque** garantissent une haute efficacité avec une réduction de la dispersion du dioxyde de carbone dans l'écosystème et l'auto-production d'énergie. Parallèlement, l'entreprise met en œuvre un **tri sélectif méticuleux**, avec des opérations de **recupération représentant 90%** du total des déchets produits.

Nous sommes fiers de notre green attitude et nous continuerons à travailler dur pour réduire notre impact environnemental et promouvoir un avenir plus durable pour tous.

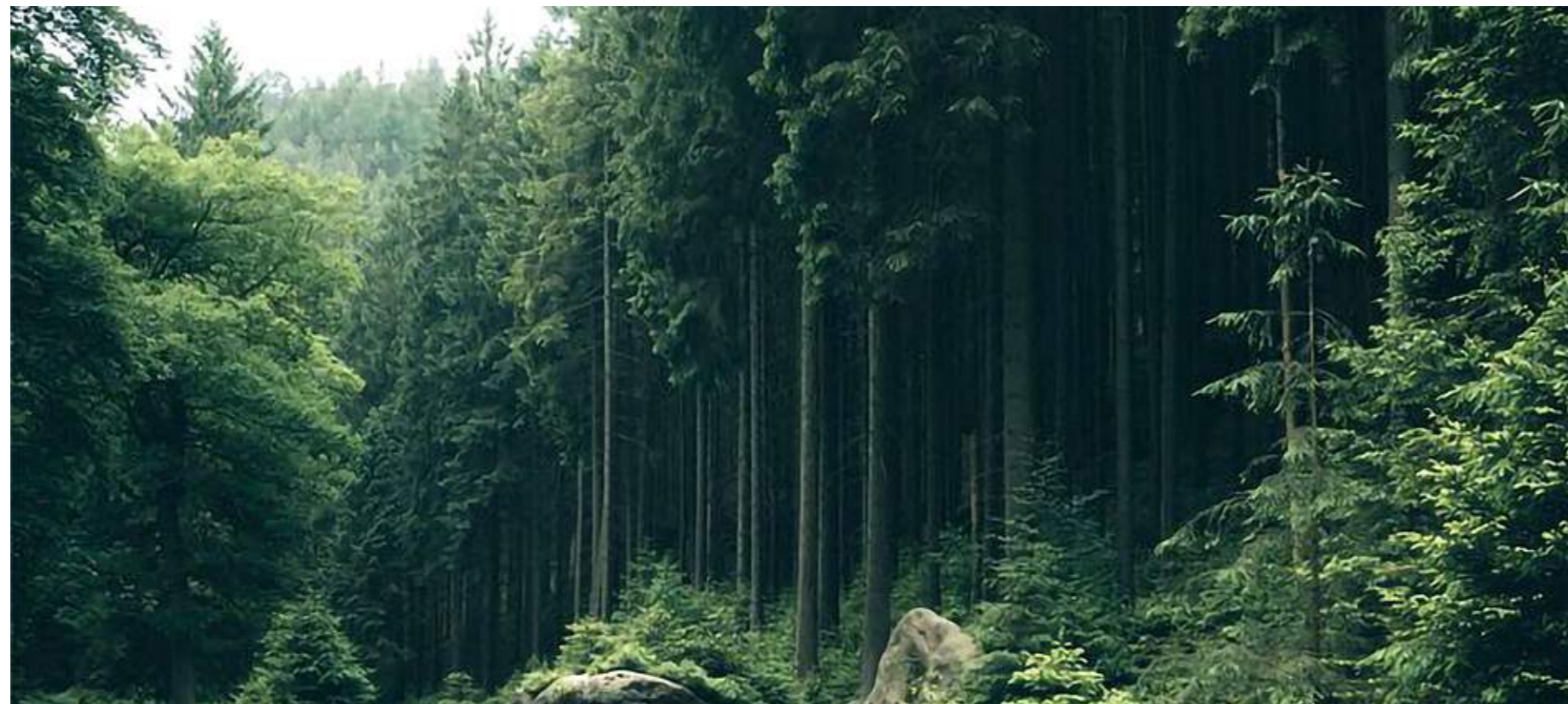



Guest

FIRE-PROOF SYSTEM
FIRE-PROOF SYSTEM

Porte Certificate per Hotel e Comunità: Garanzia di Sicurezza e Qualità

Benvenuti nel mondo delle porte certificate AGOPROFIL, un punto di riferimento per la sicurezza e la qualità nelle strutture alberghiere e comunità residenziali. Tutte le nostre porte certificate sono sottoposte a test e certificazioni da enti indipendenti, garantendo la conformità ai più elevati standard di sicurezza e qualità.

Resistenza al Fuoco: Le nostre porte certificate EI 30 EI 60, offrono un'eccellente resistenza al fuoco, essenziale per proteggere vite umane e proprietà in caso di emergenza. Testate e certificate secondo rigorosi standard di sicurezza.

Resistenza ai Fumi: Le nostre porte certificate con resistenza ai fumi sono progettate per limitare la diffusione dei gas tossici e dei vapori nocivi, proteggendo la salute e la vita degli occupanti della struttura.

Capacità Fonoassorbenti: Il comfort acustico è fondamentale per garantire un ambiente piacevole e rilassante negli hotel e nelle comunità residenziali. Le nostre porte DB 31 e DB 39, non solo offrono una protezione contro il rumore esterno, ma assorbono attivamente le onde sonore all'interno degli ambienti.

Design Personalizzato e Durabilità: Oltre alle prestazioni di sicurezza, le nostre porte certificate sono disponibili in una varietà di design e finiture per adattarsi perfettamente all'estetica e alle esigenze specifiche per ogni progetto

Certified Doors for Hotels and Communities: Guarantee of Safety and Quality

Welcome to the world of AGOPROFIL certified doors, a benchmark for safety and quality in hotel and residential community structures. All our certified doors undergo testing and certification by independent bodies, ensuring compliance with the highest standards of safety and quality.

Fire Resistance: Our EI 30 and EI 60 certified doors offer excellent fire resistance, essential for protecting human lives and property in case of emergencies. Tested and certified according to rigorous safety standards.

Smoke Resistance: Our certified doors with smoke resistance are designed to limit the spread of toxic gases and harmful vapors, providing safe evacuation routes and protecting the health and lives of the occupants of the structure.

Sound Absorption Capacity: Acoustic comfort is essential to ensure a pleasant and relaxing environment in hotels and residential communities. Our DB 31 and DB 39 doors not only offer protection against external noise but also actively absorb sound waves within the environments.

Custom Design and Durability: In addition to safety performance, our certified doors are available in a variety of designs and finishes to perfectly suit the aesthetics and specific needs of your projects.

Portes Certifiées pour Hôtels et Communautés: Garantie de Sécurité et Qualité

Bienvenue dans le monde des portes certifiées AGOPROFIL, une référence en matière de sécurité et de qualité dans les structures hôtelières et les communautés résidentielles. Toutes nos portes certifiées sont soumises à des tests et certifications par des organismes indépendants, garantissant la conformité aux normes les plus élevées en matière de sécurité et de qualité.

Résistance au Feu: Nos portes certifiées EI 30 et EI 60 offrent une excellente résistance au feu, essentielle pour protéger les vies humaines et les biens en cas d'urgence. Testées et certifiées selon des normes de sécurité rigoureuses.

Résistance aux Fumées: Nos portes certifiées avec résistance aux fumées sont conçues pour limiter la diffusion des gaz toxiques et des vapeurs nocives, protégeant ainsi la santé et la vie des occupants de la structure.

Capacité d'Absorption Sonore: Le confort acoustique est essentiel pour garantir un environnement agréable et relaxant dans les hôtels et les communautés résidentielles. Nos portes DB 31 et DB 39 offrent non seulement une protection contre le bruit extérieur, mais absorbent également activement les ondes sonores à l'intérieur des espaces.

Design Personnalisé et Durabilité: En plus des performances de sécurité, nos portes certifiées sont disponibles dans une variété de designs et de finitions pour s'adapter parfaitement à l'esthétique et aux besoins spécifiques de vos projets.



Laccati 22

LACQUERED / LAQUÉ

PURE	24
ALU in PURE	46
CRYSTAL in PURE	50
SLAB in PURE	52
STRIPE in PURE	58
SCULPTURE in PURE	68
WRINKLED in PURE	82
HYPE	92
NATIVE	142
EDITIONS	148
SOLID	160
PRESTIGE	170
MATERIKA MTK	248
LEGGERA	256

Texture 266

TEXTURE / TEXTURE

EXEA	266
ALU in EXEA	268
CRYSTAL in EXEA	270
SLAB in EXEA	272
STRIPE in EXEA	274

Legni 338

WOOD / BOIS

WOODY	338
ALU in WOODY	340
SLAB in WOODY	342
STRIPE in WOODY	344

Glass 382

GLASSES / VITRES

ART GLASS	388
------------------	------------

Zero-Wall System 408

ZERO-WALL SYSTEM / ZERO-WALL SYSTEM

HIDE	410
CLOUD	412
FLY	414

Maniglie, Accessori e Finiture 416

HANDLES, ACCESSORIES AND FINISHES
POIGNÉES, ACCESSORIES ET FINITIONS

HANDLES	418
----------------	------------

Laccati

LACQUERED / LAQUÉ



PURE
Liscio Laccato

SMOOTH BLIND DOOR
PORTE AVEUGLE LISSE



MINORCA



MINORCA



MINORCA

PURE

Spazzolato Laccato

SPAZZOLATO LACQUERED
SPAZZOLATO LAQUÉ



*
Porte con telaio e coprifilo SPAZZOLATO
Doors with SPAZZOLATO Frame and Casing
Portes avec Cadre et Couvre-joints SPAZZOLATO

F Y N *

SPAZZOLATO ORIZZONTALE
HORIZONTAL SPAZZOLATO
SPAZZOLATO HORIZONTAL

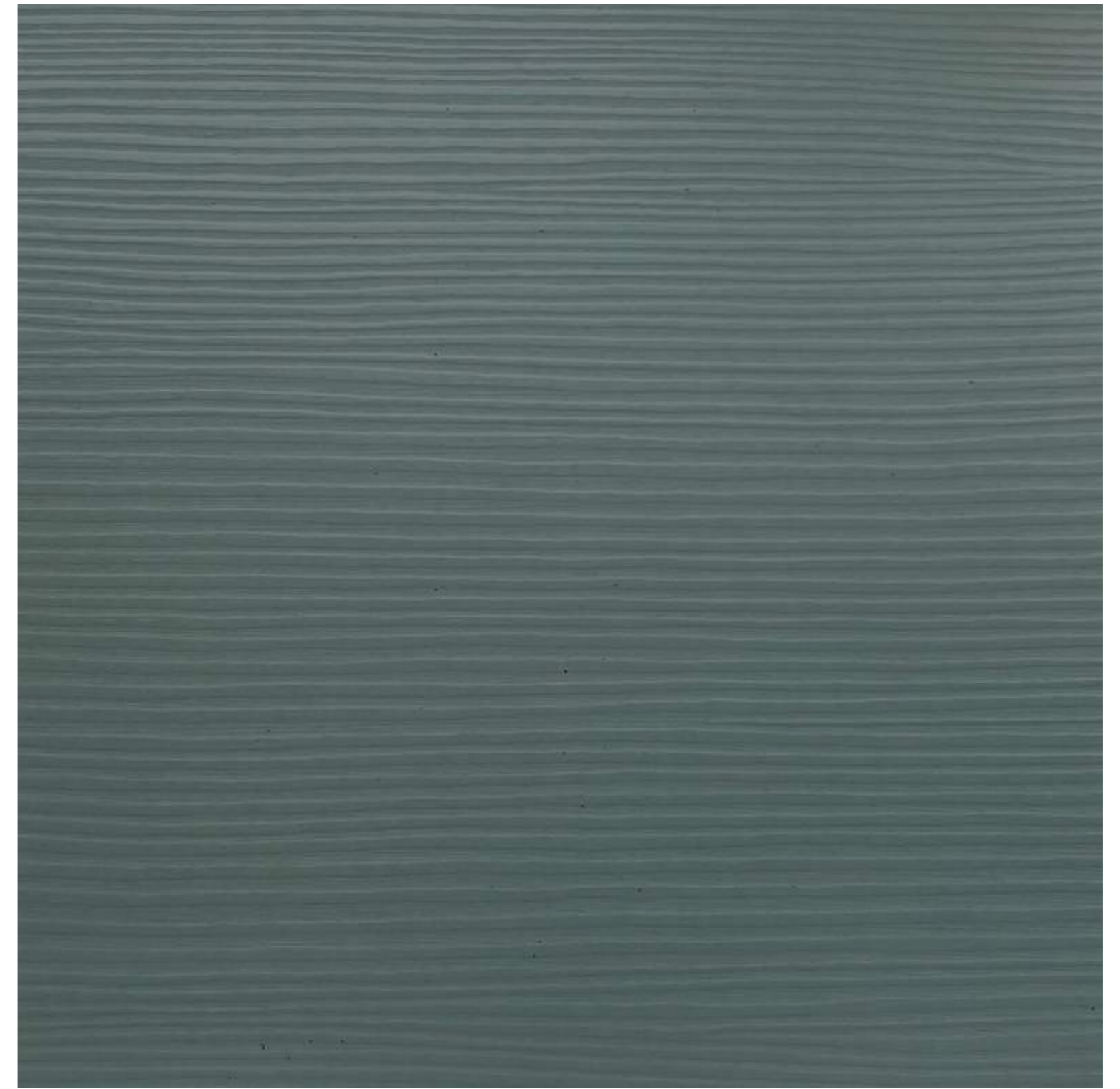

PARTICOLARE SPAZZOLATO LACCATO ORIZZONTALE
SPAZZOLATO LACQUERED HORIZONTAL DETAIL
DÉTAIL SPAZZOLATO HORIZONTAL LAQUÉ

PURE

Spazzolato Laccato

SPAZZOLATO LACQUERED
SPAZZOLATO LAQUÉ



*
Porte con telaio e coprifilo SPAZZOLATO
Doors with SPAZZOLATO Frame and Casing
Portes avec Cadre et Couvre-joints SPAZZOLATO

SKYE*
SPAZZOLATO VERTICALE
VERTICAL SPAZZOLATO
SPAZZOLATO VERTICAL



PARTICOLARE SPAZZOLATO LACCATO VERTICALE
SPAZZOLATO LACQUERED VERTICAL DETAIL
DÉTAIL SPAZZOLATO VERTICAL LAQUÉ

PURE

Poroaperto Laccato

POROAPERTO LACQUERED
POROAPERTO LAQUÉ



*
Porte con telaio e coprifilo LISCIO
Doors with SMOOTH Frame and Casing
Portes avec Cadre et Couvre-joints LISSE

SENIA*
POROAPERTO ORIZZONTALE
HORIZONTAL POROAPERTO
POROAPERTO HORIZONTAL



PARTICOLARE POROAPERTO LACCATO ORIZZONTALE
POROAPERTO LACQUERED HORIZONTAL DETAIL
DÉTAIL POROAPERTO HORIZONTAL LAQUÉ

PURE

Poroaperto Laccato

POROAPERTO LACQUERED
POROAPERTO LAQUÉ



HAIMAN*

POROAPERTO VERTICALE
VERTICAL POROAPERTO
POROAPERTO VERTICAL

*
Porte con telaio e coprifilo LISCIO
Doors with SMOOTH Frame and Casing
Portes avec Cadre et Couvre-joints LISSE



PARTICOLARE POROAPERTO LACCATO VERTICALE
POROAPERTO LACQUERED VERTICAL DETAIL
DÉTAIL POROAPERTO VERTICAL LAQUÉ

PURE Frassino Laccato

FRASSINO LACQUERED
FRASSINO LAQUÉ



ANTILIA*

FRASSINO ORIZZONTALE
HORIZONTAL FRASSINO
FRASSINO HORIZONTAL

* Anta Frassino. Telaio e Coprifilo LISCIO
Frassino Panel. SMOOTH Frame and Casing
Panneau Laques. Cadre et Couvre-joints LISSE



PARTICOLARE FRASSINO LACCATO ORIZZONTALE
FRASSINO LACQUERED HORIZONTAL DETAIL
DÉTAIL FRASSINO HORIZONTAL LAQUÉ

PURE
Frassino Laccato

FRASSINO LACQUERED
FRASSINO LAQUÉ



TAUMAR*

* Anta Frassino. Telaio e Coprifilo LISCIO
Frassino Door. SMOOTH Frame and Casing
Panneau Laques. Cadre et Couvre-joints LISSE

FRASSINO VERTICALE
VERTICAL FRASSINO
FRASSINO VERTICAL

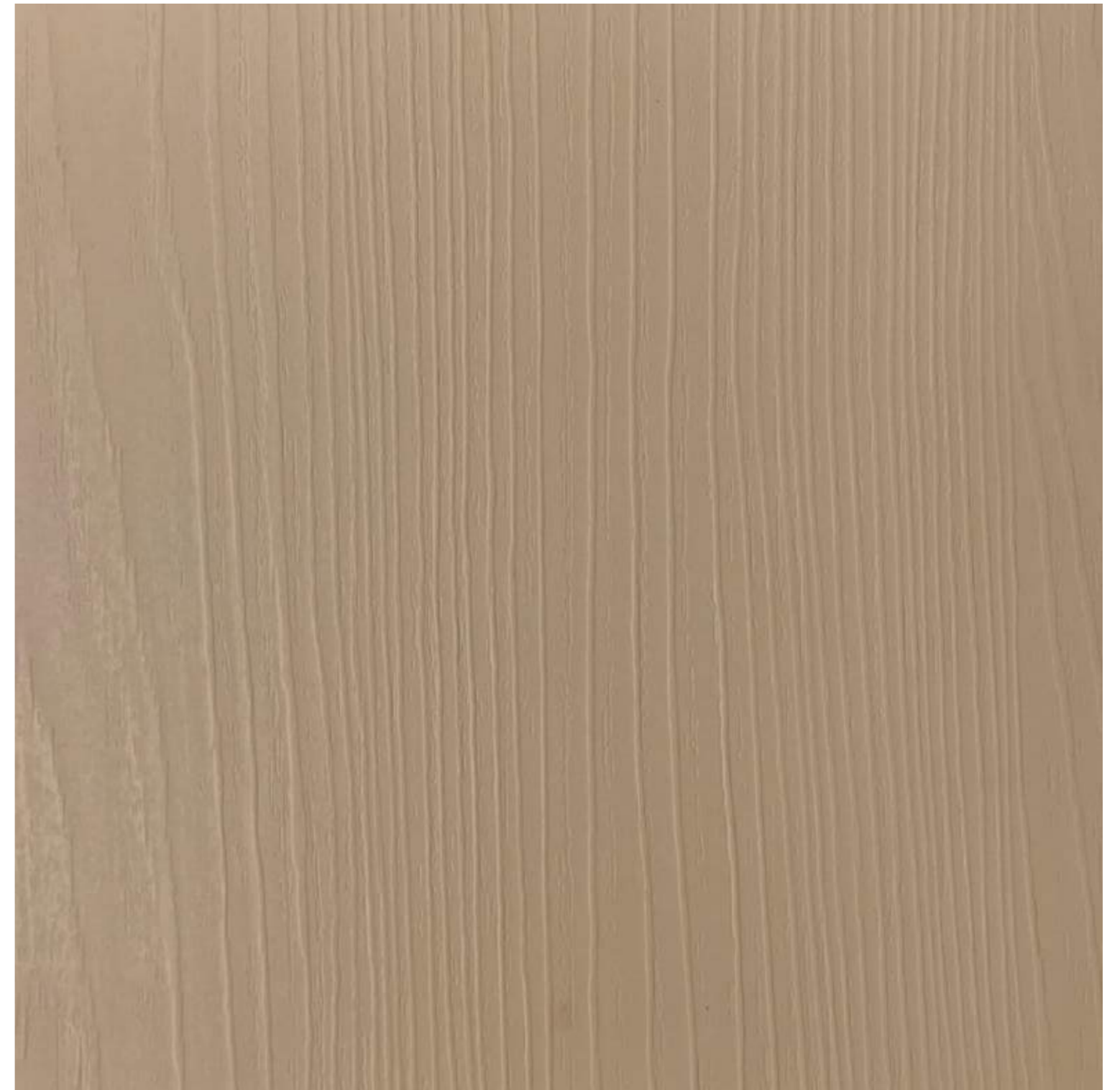

PARTICOLARE FRASSINO LACCATO VERTICALE
FRASSINO LACQUERED VERTICAL DETAIL
DÉTAIL FRASSINO VERTICAL LAQUÉ

PURE Rovere Laccato

ROVERE LACQUERED
ROVERE LAQUÉ



BLONDIE*

ROVERE ORIZZONTALE
HORIZONTAL ROVERE
ROVERE HORIZONTAL

* Anta Rovere. Telaio e Coprifilo LISCIO
Rovere Panel. SMOOTH Frame and Casing
Rovere Laques. Cadre et Couvre-joints LISSE



PARTICOLARE ROVERE LACCATO ORIZZONTALE
ROVERE LACQUERED HORIZONTAL DETAIL
DÉTAIL ROVERE HORIZONTAL LAQUÉ

PURE
Rovere Laccato

ROVERE LACQUERED
ROVERE LAQUÉ



BRENDA*

ROVERE VERTICALE
VERTICAL ROVERE
ROVERE VERTICAL

*
Anta Rovere. Telaio e Coprifilo LISCIO
Rovere Panel. SMOOTH Frame and Casing
Rovere Laques. Cadre et Couvre-joints LISSE



PARTICOLARE ROVERE LACCATO VERTICALE
ROVERE LACQUERED VERTICAL DETAIL
DÉTAIL ROVERE VERTICAL LAQUÉ

PURE
Mineral Laccato

MINERAL LACQUERED
MINERAL LAQUÉ



*
Porte con telaio e coprifilo LISCIO
Doors with SMOOTH Frame and Casing
Portes avec Cadre et Couvre-joints LISSE

S A B E A *



PARTICOLARE MINERAL LACCATO
LACQUERED MINERAL DETAIL
DÉTAIL MINERAL LAQUÉ

PURE Self Finishing

SELF-FINISHING
FINITION - SELF

Rappresentata tonalizzata con tinta muro
Represented toned with wall color
Représenté avec la couleur du mur



MINORCA SELF

ALU in PURE - Inserti in Alluminio

ALUMINIUM INSERTS
BAGUETTES EN ALUMINIUM



PARTICOLARE INSERTO ALLUMINIO
ALUMINUM INSERT DETAIL
DÉTAIL INSERT EN ALUMINIUM

ALU in PURE

ALU IN PURE
ALU IN PURE



AY NEROMAT
IN MINORCA



AZ CROMO*
IN TAUMAR



AN VINTAGEMAT*
IN SABEA

*
Porte con telaio e coprifilo LISCIO
Doors with SMOOTH Frame and Casing
Portes avec Cadre et Couvre-joints LISSE

CRYSTAL in PURE - Versione Vetro

GLASS VERSION
VERSION POUR VITRE



V. MINIMAL
IN...



V. TOTAL
IN...



V. TRIAL
IN...



V. DUAL
IN...



TRASPARENTE
BIANCO



TRASPARENTE
BRONZO



TRASPARENTE
FUMÈ



SATINATO
BIANCO

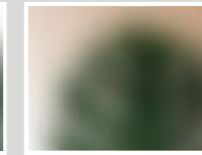

SATINATO
BRONZO

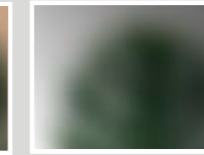

SATINATO
FUMÈ



SPECCHIO
2 LATI



... MINORCA



... FYN



... SKYE



... SENIA



... HAIMAN



... ANTLIA



... TAUMAR



... BLONDIE



... BRENDA



... SABEA...



PARTICOLARE FERMAVETRO
GLASS HOLDER DETAIL
DÉTAIL PORTE-VITRE

SLAB in PURE - Vetro Strutturale

STRUCTURAL GLASS
VITRE STRUCTUREL



V. AVENUE
IN...

V. PLACE
IN...

V. ROAD
IN...

V. SLIM
IN...

V. FINGER
IN...



TRASPARENTE
BIANCO

TRASPARENTE
BRONZO

TRASPARENTE
FUMÈ

SATINATO
BIANCO

SATINATO
BRONZO

SATINATO
FUMÈ

SPECCHIO
2 LATI



...MINORCA



...FYN



...SKYE



...SENIA



...HAIMAN



...ANTILIA



...TAUMAR



...BLONDIE



...BRENDA



...SABEA...



PARTICOLARE VETRO STRUTTURALE STRATIFICATO 4+4
STRUCTURAL STRATIFIED GLASS 4+4 DETAIL
DÉTAIL VITRE STRATIFIÉ 4+4 STRUCTUREL

SLAB in PURE

SLAB IN PURE
SLAB IN PURE



V.SLIM*
IN BLONDIE

*
Porte con telaio e coprifilo LISCI
Doors with SMOOTH Frame and Casing
Portes avec Cadre et Couvre-joints LISSE



V.FINGER*
IN MINORCA

SLAB in PURE

SLAB IN PURE
SLAB IN PURE



V. AVENUE*
IN MINORCA



V. ROAD*
IN MINORCA

*
Porte con telaio e coprifilo LISCI
Doors with SMOOTH Frame and Casing
Portes avec Cadre et Couvre-joints LISSE



V. PLACE*
IN MINORCA

STRIPE in PURE - Vetrolaccato

BACK PAINTED GLASS
VITRE RETROLAQUÈ



PARTICOLARE VETRO RETROLACCATO - LUCE NON PASSANTE
BACK-PAINTED LACQUERED GLASS DETAIL - NON TRANSPARENT
DÉTAIL DU VITRE RÉTROLAQUÉ - NON TRASPARENTE

STRIPE in PURE

STRIPE IN PURE
STRIPE IN PURE



VTV*
IN MINORCA

*
Porte con telaio e coprifilo LISCIO
Doors with SMOOTH Frame and Casing
Portes avec Cadre et Couvre-joints LISSE



VLV*
IN MINORCA

STRIPE in PURE

STRIPE IN PURE
STRIPE IN PURE



VGO*
IN S A B E A

*
Porte con telaio e coprifilo LISCIO
Doors with SMOOTH Frame and Casing
Portes avec Cadre et Couvre-joints LISSE



VLV*
IN S A B E A

STRIPE in PURE

STRIPE IN PURE
STRIPE IN PURE



VGV*
IN TAUMAR

*
Porte con telaio e coprifilo LISCIO
Doors with SMOOTH Frame and Casing
Portes avec Cadre et Couvre-joints LISSE



VTV*
IN TAUMAR

STRIPE in PURE

STRIPE IN PURE
STRIPE IN PURE



VGV*
IN HAIMAN

*
Porte con telaio e coprifilo LISCIO
Doors with SMOOTH Frame and Casing
Portes avec Cadre et Couvre-joints LISSE



VGO*
IN SENIA

SCULPTURE in PURE

SCULPTURES
SCULPTURES



AMULENA
IN...



NARDEA
IN...



IRAMANA
IN...



MORASEY
IN...



NARASON
IN...



DULAICA
IN...



ASESILA
IN...



PARTICOLARE SCULTURE
SCULPTURE DETAIL
DÉTAIL SCULPTURE



ALAR
IN...



ANIGAV
IN...



DAIARI
IN...



ZIRAR
IN...



TILDEAM
IN...



ENELAI
IN...



GARYB
IN...



NETARICA
IN...



...MINORCA



...FYN



...SKYE



...SENIA



...HAIMAN



...ANTILIA



...TAUMAR



...BLONDIE



...BRENDA



...SABEA...

SCULPTURE in PURE

SCULPTURE IN PURE
SCULPTURE IN PURE



NARDEA
IN MINORCA*

*
Porte con telaio e coprifilo LISCIO
Doors with SMOOTH Frame and Casing
Portes avec Cadre et Couvre-joints LISSE



ANIGAV
IN MINORCA*

SCULPTURE in PURE

SCULPTURE IN PURE
SCULPTURE IN PURE



ZIRAR
IN MINORCA*

*
Porte con telaio e coprifilo LISCIO
Doors with SMOOTH Frame and Casing
Portes avec Cadre et Couvre-joints LISSE



DAIARI
IN SABEA*

SCULPTURE in PURE

SCULPTURE IN PURE
SCULPTURE IN PURE



AMULENA
IN HAIMAN*



NARASON
IN MINORCA*

*
Porte con telaio e coprifilo LISCI
Doors with SMOOTH Frame and Casing
Portes avec Cadre et Couvre-joints LISSE



IRAMANA
IN MINORCA*

SCULPTURE in PURE

SCULPTURE IN PURE
SCULPTURE IN PURE



ASESILA
IN MINORCA*



MORASEY
IN MINORCA*

*
Porte con telaio e coprifilo LISCI
Doors with SMOOTH Frame and Casing
Portes avec Cadre et Couvre-joints LISSE



ALAR
IN MINORCA*

SCULPTURE in PURE

SCULPTURE IN PURE
SCULPTURE IN PURE



DULAICA
IN MINORCA*

*
Porte con telaio e coprifilo LISCIO
Doors with SMOOTH Frame and Casing
Portes avec Cadre et Couvre-joints LISSE



NETARICA
IN MINORCA*

SCULPTURE in PURE

SCULPTURE IN PURE
SCULPTURE IN PURE



TILDEAM
IN MINORCA*



GARYB
IN MINORCA*

*
Porte con telaio e coprifilo LISCI
Doors with SMOOTH Frame and Casing
Portes avec Cadre et Couvre-joints LISSE



ENELAI
IN MINORCA*

WRINKLED in PURE

WRINKLED
WRINKLED



ARGOS
IN...



YAMANA
IN...



SUMATRA
IN...



AVALON
IN...



BRITTA
IN...



KRAKOA
IN...



DAVIS
IN...

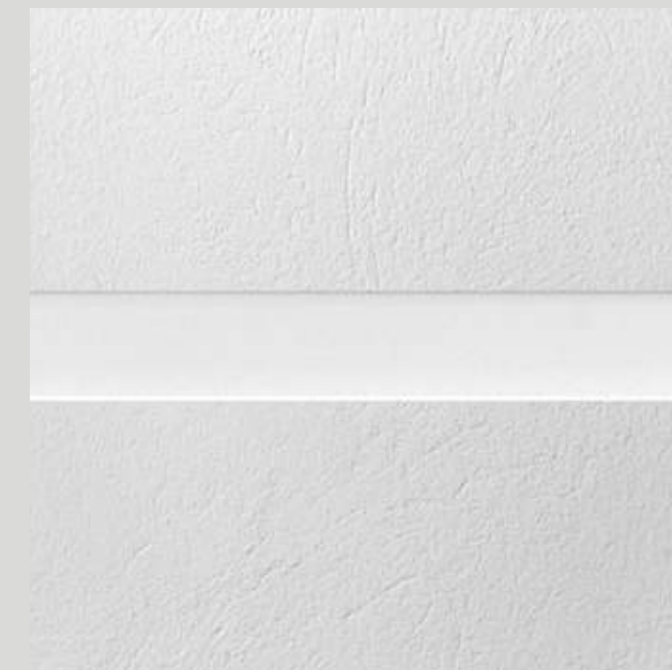

PARTICOLARE WRINKLED
WRINKLED DETAIL
DÉTAIL WRINKLED



...MINORCA



...FYN



...SKYE



...SENIA



...HAIMAN



...ANTILIA



...TAUMAR



...BLONDIE



...BRENDA



...SABEA...

WRINKLED in PURE

WRINKLED IN PURE
WRINKLED IN PURE



*
Porte con telaio e coprifilo LISCIO
Doors with SMOOTH Frame and Casing
Portes avec Cadre et Couvre-joints LISSE

ARGOS
IN SENIA*

WRINKLED in PURE

WRINKLED IN PURE
WRINKLED IN PURE



AVALON*
IN ANTILIA

*
Porte con telaio e coprifilo LISCIO
Doors with SMOOTH Frame and Casing
Portes avec Cadre et Couvre-joints LISSE



AVALON
IN ANTILIA*

WRINKLED in PURE

WRINKLED IN PURE
WRINKLED IN PURE



YAMANA*
IN S A B E A



SUMATRA*
IN S A B E A

*
Porte con telaio e coprifilo LISCI
Doors with SMOOTH Frame and Casing
Portes avec Cadre et Couvre-joints LISSE



YAMAMA*
IN B L O N D I E

WRINKLED in PURE

WRINKLED IN PURE
WRINKLED IN PURE



BRITTA*
IN MINORCA



KRAKOA*
IN TAUMAR

*
Porte con telaio e coprifilo LISCIO
Doors with SMOOTH Frame and Casing
Portes avec Cadre et Couvre-joints LISSE



DAVIS*
IN TAUMAR

HYPE - Easy Incise

ENGRAVED EASY
GRAVURE EASY



ITAPARICA
EASY



FORMENTERA
EASY



ESPALMADOR
EASY



TAHAA
EASY



BORA BORA
EASY



LANZAROTE
EASY



MILOS
EASY



SULASAR
EASY



LYSANDRA
EASY



AFIBANA
EASY



SIMOSMA
EASY



NARAINA
EASY



SENAVAS
EASY



RESETA
EASY



CUBA
EASY



MELVILLE
EASY



MEJA
EASY



CERAM
EASY



GEORGIA
EASY



BRITANNIA
EASY



IRLANDA
EASY



RONHAS
EASY



TEKE
EASY



FINOA
EASY



SANTAINES
EASY



IKON
EASY



XENA
EASY



SHEILA
EASY



ATAN
EASY



TARANAKI
EASY



TYPAN
EASY



DHIBA-P
EASY



WELLIGTON-P
EASY



PORTORICO-P
EASY



SAOTIAGO-P
EASY



PARTICOLARE INCISIONE EASY
EASY ENGRAVED DETAIL
DÉTAIL GRAVURE EASY

HYPE - Plus Incise

ENGRAVED PLUS
GRAVURE PLUS



ITAPARICA
PLUS



FORMENTERA
PLUS



ESPALMADOR
PLUS



TAHAA
PLUS



BORA BORA
PLUS



LANZAROTE
PLUS



MILOS
PLUS



CUBA
EASY



MELVILLE
PLUS



CERAM
PLUS Y



GEORGIA
PLUS



BRITANNIA
PLUS



IRLANDA
PLUS



SANTAINES
PLUS



IKON
PLUS



XENA
PLUS



SHEILA
PLUS



SULASAR
PLUS



TEKE
PLUS

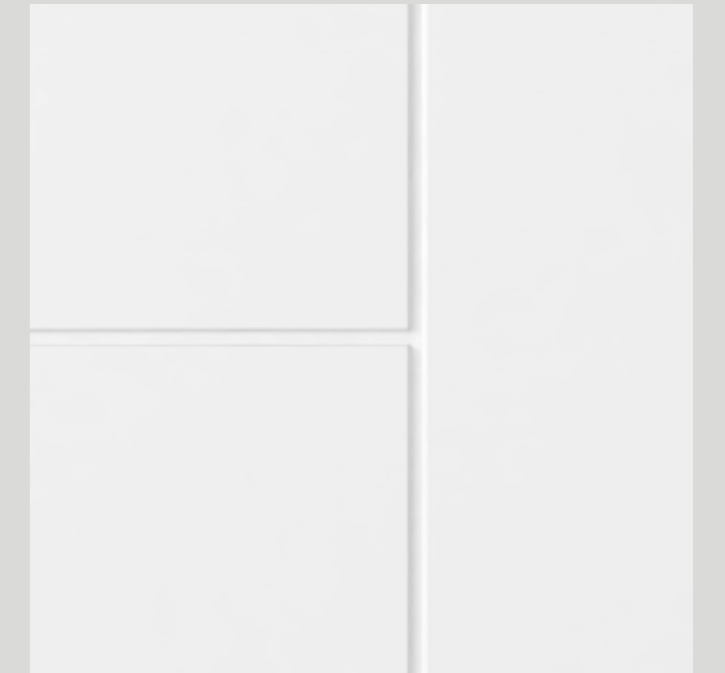

PARTICOLARE INCISIONE PLUS
ENGRAVED PLUS DETAIL
DÉTAIL GRAVURE PLUS

HYPE - Easy Incise Vetro

ENGRAVED EASY GLASS VERSION
EASY GRAVÉ VERSION POUR VITRE



D H I B A - V
E A S Y



W E L L I N G T O N - V
E A S Y



P O R T O R I C O - V
E A S Y



S A O T I A G O - V
E A S Y



TRASPARENTE
BIANCO



TRASPARENTE
BRONZO



TRASPARENTE
FUMÈ



SATINATO
BIANCO

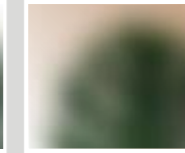

SATINATO
BRONZO

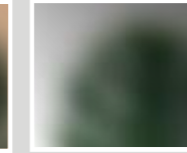

SATINATO
FUMÈ

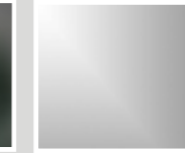

SPECCHIO
2 LATI

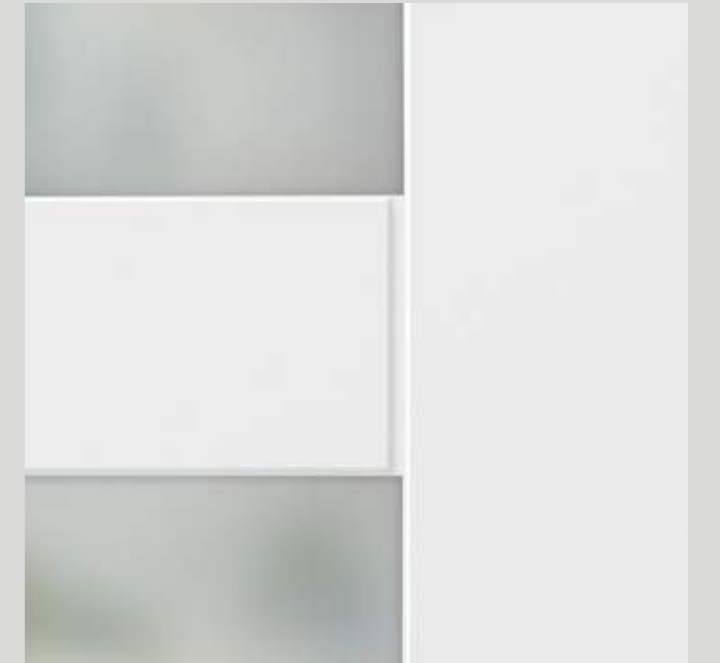

PARTICOLARE INCISIONE EASY CON VETRO
ENGRAVED EASY WITH GLASS DETAIL
DÉTAIL EASY VITRÉE GRAVÉ

HYPE Inciso Laccato

ENGRAVED LACQUERED
GRAVÉ LAQUÉ



FORMENTERA



ESPALMADOR



FORMENTERA

HYPE Inciso Laccato

ENGRAVED LACQUERED
GRAVÉ LAQUÉ

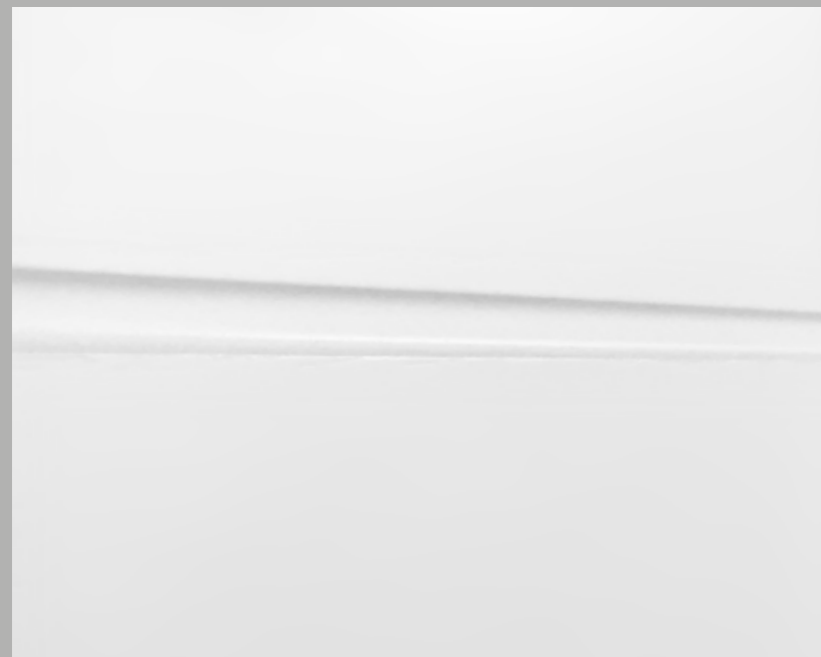

T A H A A



B O R A B O R A

HYPE Inciso Laccato

ENGRAVED LACQUERED
GRAVÉ LAQUÉ



HYPE
Inciso Laccato

ENGRAVED LACQUERED
GRAVÉ LAQUÉ



HYPE Inciso Laccato

ENGRAVED LACQUERED
GRAVÉ LAQUÉ



CUBA



MELVILLE



MEJA

HYPE
Inciso Laccato

ENGRAVED LACQUERED
GRAVÉ LAQUÉ



GEORGIA



GEORGIA

HYPE
Inciso Laccato

ENGRAVED LACQUERED
GRAVÉ LAQUÉ



BRITANNIA



IRLANDA



SANTAINES

HYPE Inciso Laccato

ENGRAVED LACQUERED
GRAVÉ LAQUÉ



CERAM

V. AVENUE
IN MINORCA

HYPE Inciso Laccato

ENGRAVED LACQUERED
GRAVÉ LAQUÉ



HYPE Inciso Laccato

ENGRAVED LACQUERED
GRAVÉ LAQUÉ

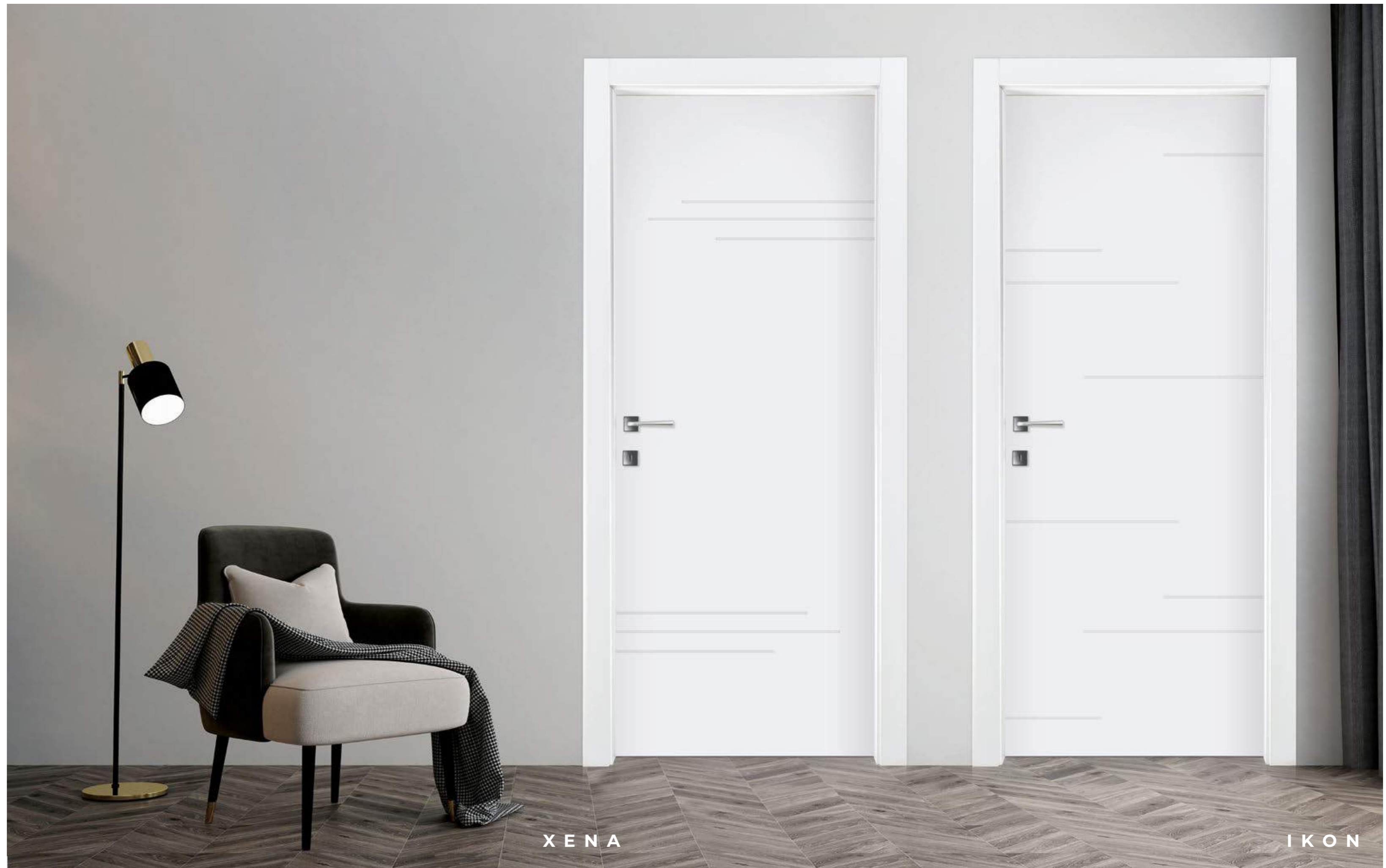

XENA

IKON

HYPE Inciso Laccato

ENGRAVED LACQUERED
GRAVÉ LAQUÉ



ATAN



TYPAN



ATAN

HYPE Inciso Laccato

ENGRAVED LACQUERED
GRAVÉ LAQUÉ



TARANAKI



TARANAKI

HYPE Inciso Laccato

ENGRAVED LACQUERED
GRAVÉ LAQUÉ



SHEILA



LYSANDRA



LYSANDRA

HYPE Inciso Laccato

ENGRAVED LACQUERED
GRAVÉ LAQUÉ



A F I B A N A



S U L A S A R



N A R A I N A
MatteoRagniStudio

HYPE Inciso Laccato

ENGRAVED LACQUERED
GRAVÉ LAQUÉ



SENAVAS



SIMOSMA

HYPE Inciso Laccato

ENGRAVED LACQUERED
GRAVÉ LAQUÉ



TEKE



TEKE

HYPE Inciso Laccato

ENGRAVED LACQUERED
GRAVÉ LAQUÉ



HYPE Inciso Laccato

ENGRAVED LACQUERED
GRAVÉ LAQUÉ



RESETA



RONHAS



RONHAS

HYPE Inciso Laccato

ENGRAVED LACQUERED
GRAVÉ LAQUÉ



FINOA



FINOA



FINOA

HYPE Inciso Laccato

ENGRAVED LACQUERED
GRAVÉ LAQUÉ



DHIBA - P



DHIBA - V



DHIBA - P

HYPE Inciso Laccato

ENGRAVED LACQUERED
GRAVÉ LAQUÉ



WELLINGTON-V



WELLINGTON-P



PORTORICO-V



PORTORICO-P

HYPE Inciso Laccato

ENGRAVED LACQUERED
GRAVÉ LAQUÉ



SAOTIAGO - P



SAOTIAGO - V



SAOTIAGO - P



ENGRAVED EASY/PLUS
GRAVURE EASY/PLUS



CAT
EASY/PLUS



COLIBRÌ
EASY/PLUS



WATERARUM
EASY/PLUS



ROSE
EASY/PLUS



TREE
EASY/PLUS



WATERLILY
EASY/PLUS



PARTICOLARE INCISIONE EASY
EASY ENGRAVED DETAIL
DÉTAIL GRAVURE EASY

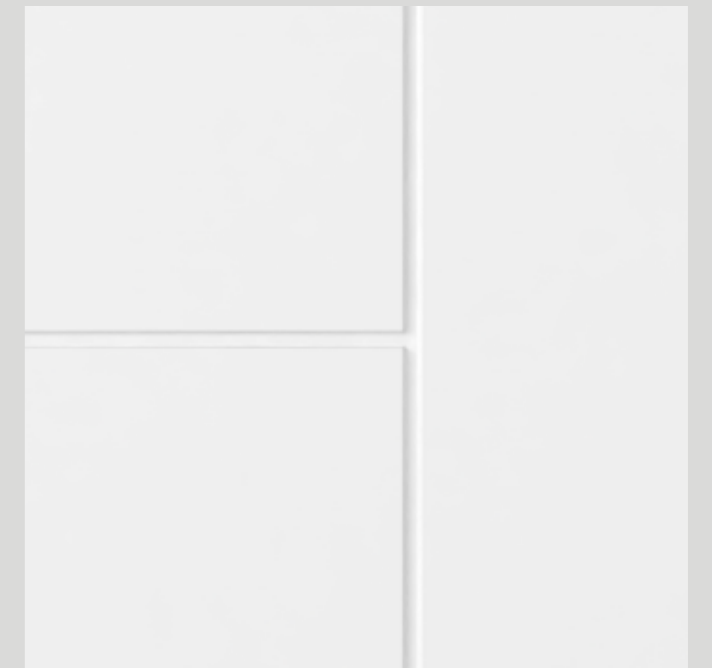

PARTICOLARE INCISIONE PLUS
ENGRAVED PLUS DETAIL
DÉTAIL GRAVURE PLUS

Native

Inciso Laccato

ENGRAVED LACQUERED
GRAVÉ LAQUÉ



COLIBRÌ



CAT



WATERLILY

Native
Inciso Laccato

ENGRAVED LACQUERED
GRAVÉ LAQUÉ



WATERARUM



ROSE



TREE

ENGRAVED EDITIONS
GRAVURE EDITIONS



GALLE



CROSS



JUMBLE



AMA



WAVE



PARTICOLARE INCISA EDITIONS
EDITIONS ENGRAVED DETAIL
DÉTAIL GRAVURE EDITIONS

editions
design collection

Inciso Laccato

ENGRAVED LACQUERED
GRAVÉ LAQUÉ

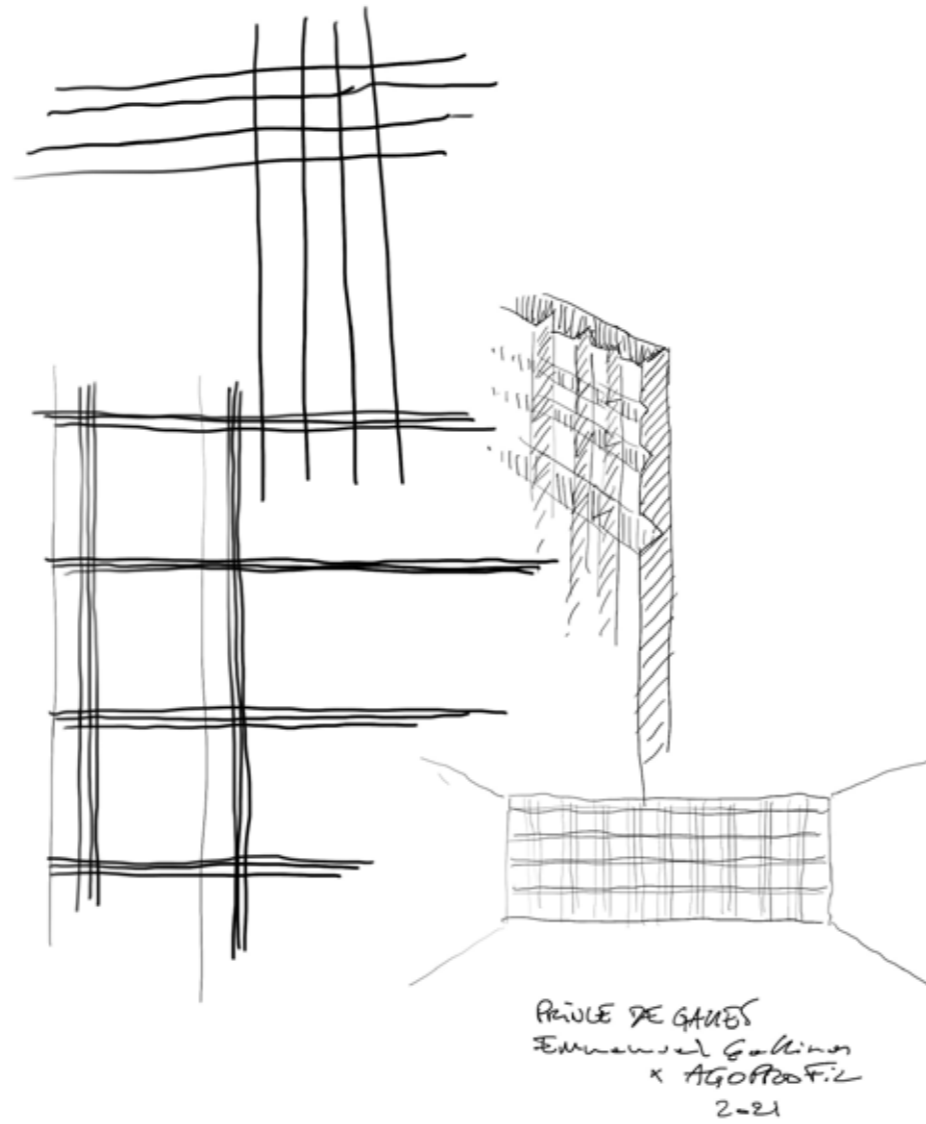

EMMANUEL GALLINA
“Una texture tridimensionale e sofisticata”
“A three-dimensional and sophisticated texture”



GALLES

editions
design collection

Inciso Laccato

ENGRAVED LACQUERED
GRAVÉ LAQUÉ

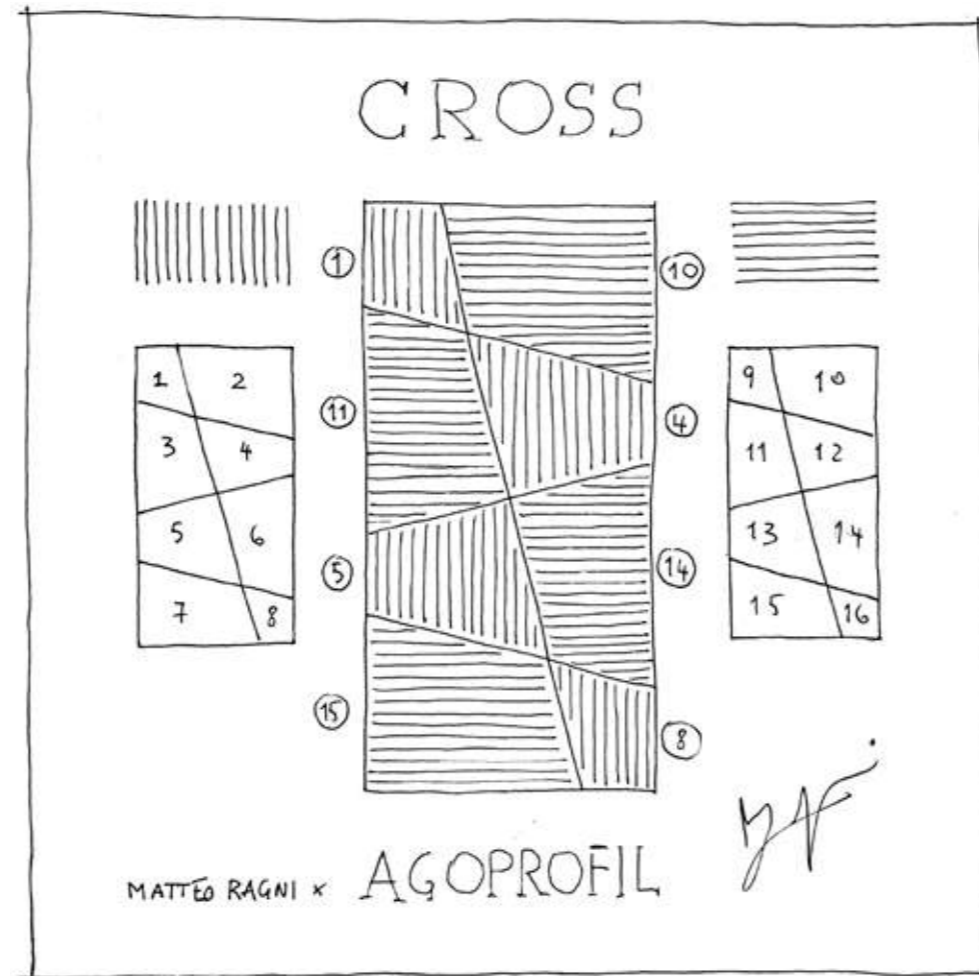

MATTEO RAGNI

“Una collezione che esalta l'elemento grafico del progetto,
dove la modularità e il segno sono protagonisti assoluti”

“A collection that enhances the graphic element of the project,
where modularity and sign are the absolute protagonists”



editions
design collection

Inciso Laccato

ENGRAVED LACQUERED
GRAVÉ LAQUÉ

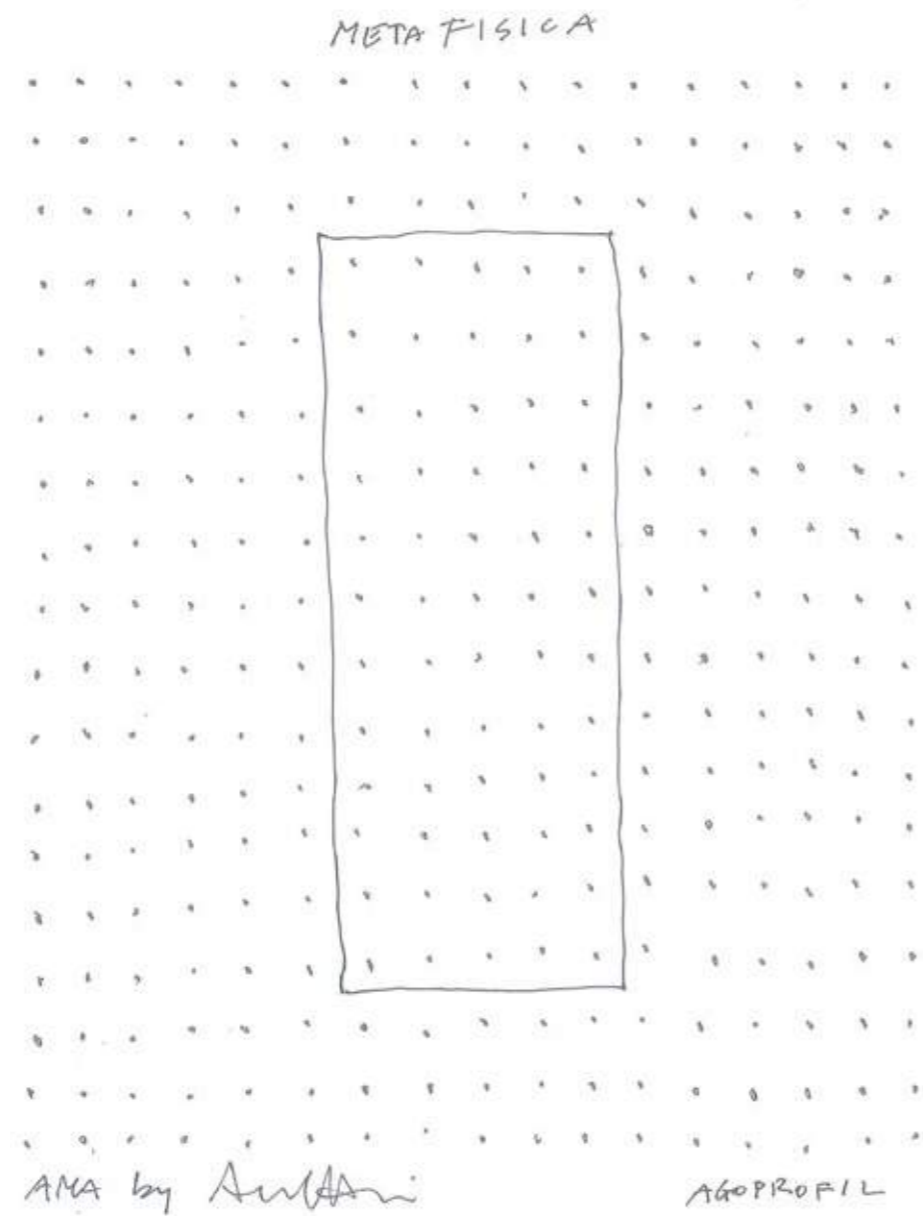

A N D R E A M A F F E I

“Un ritmo simmetrico di punti verso la metafisica della forma”
“A symmetric rhythm of points towards the metaphysics of form”



A M A

editions
design collection

Inciso Laccato

ENGRAVED LACQUERED
GRAVÉ LAQUÉ

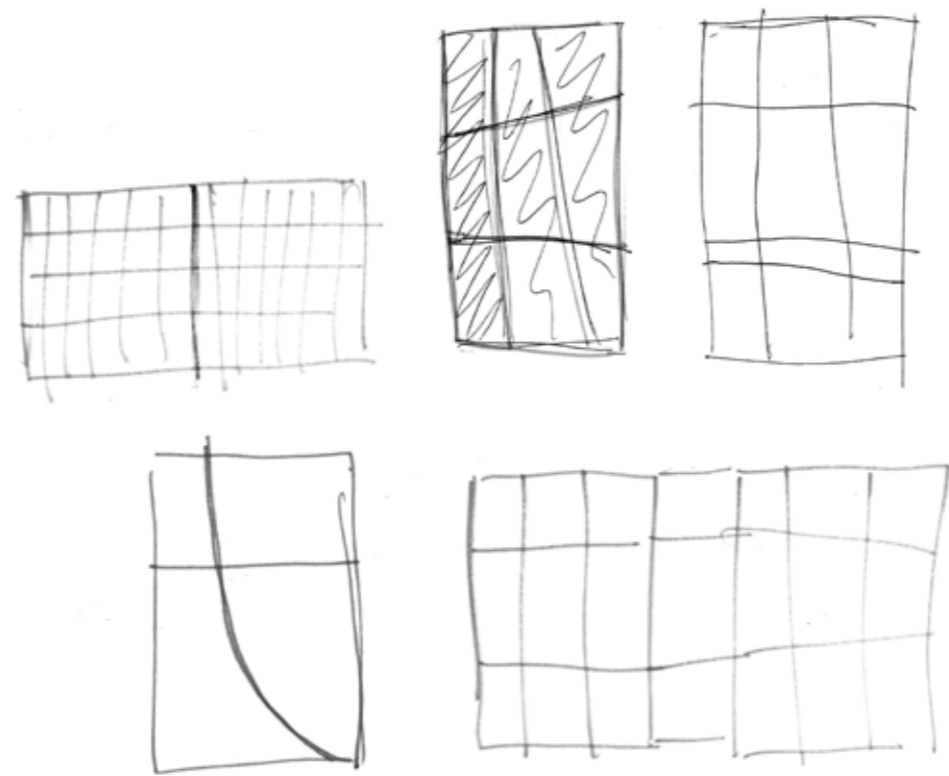

LUCA NICHETTO

**“Elementi grafici in un design senza tempo,
rendono omaggio alla libertà dell’atto creativo”**

“Graphic elements in a timeless design,
pay tribute to the freedom of the creative act”



J U M B L E

editions
design collection

Inciso Laccato

ENGRAVED LACQUERED
GRAVÉ LAQUÉ

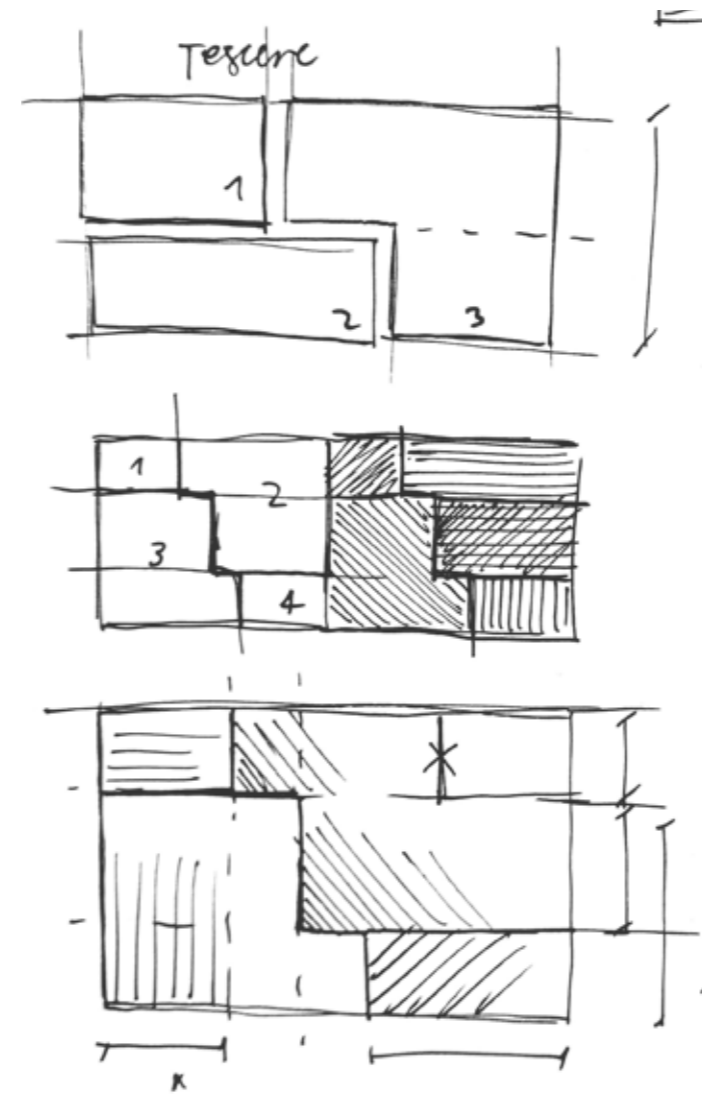

E F R E M B O N A C I N A

“L'accostamento di sagome semplici crea effetti visivi intriganti senza soluzione di continuità”

“The combination of simple shapes creates intriguing visual effects”



W A V E

SOLID

SOLID
SOLID



AXEL



BIRKIN



BYRON



CLIDE

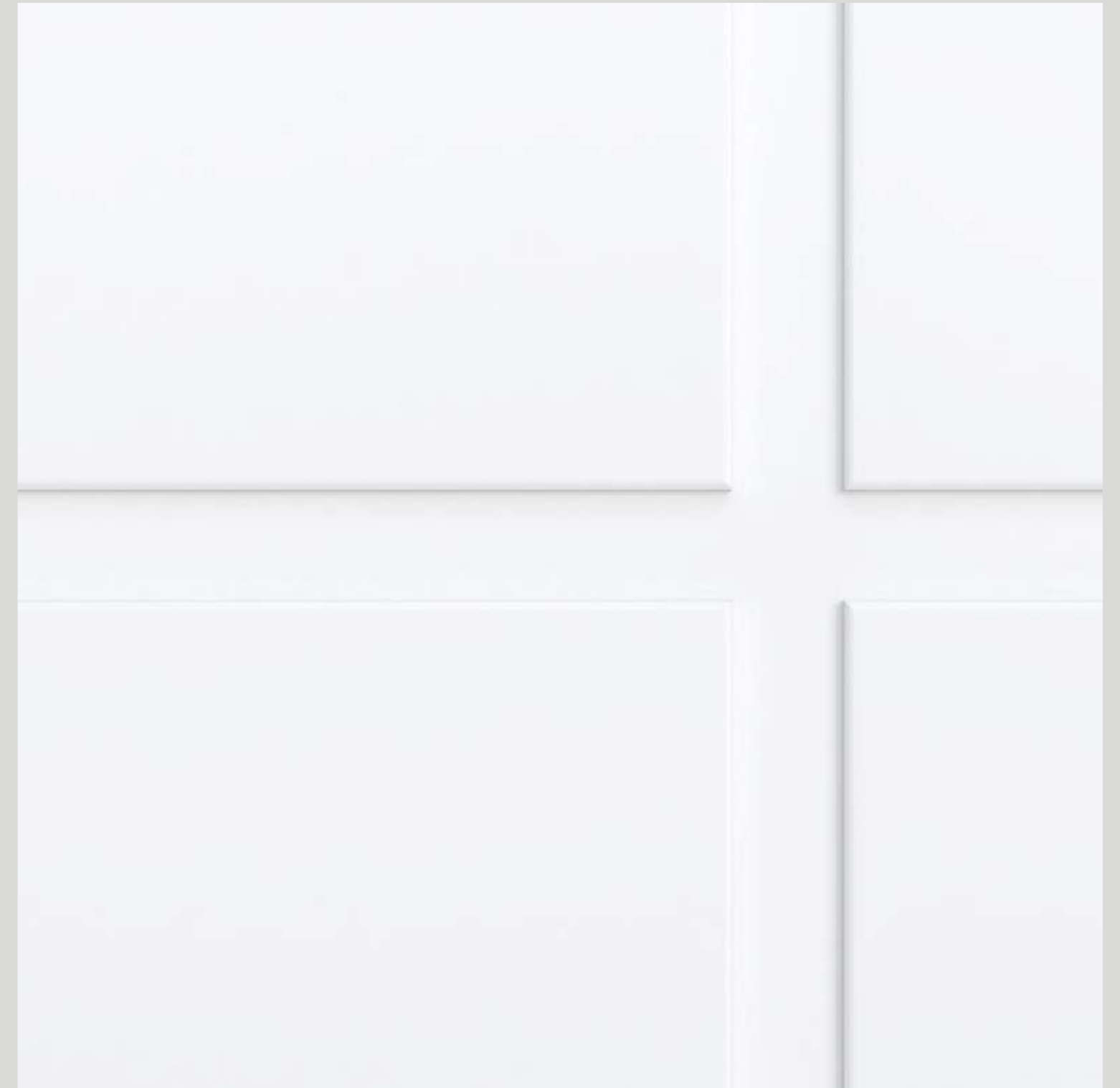

PARTICOLARE SOLID
SOLID DETAIL
DÉTAIL SOLID

SOLID

SOLID
SOLID



A X E L



A X E L

SOLID

SOLID
SOLID



BYRON



BIRKIN

SOLID

SOLID
SOLID



BIRKIN

SOLID

SOLID
SOLID

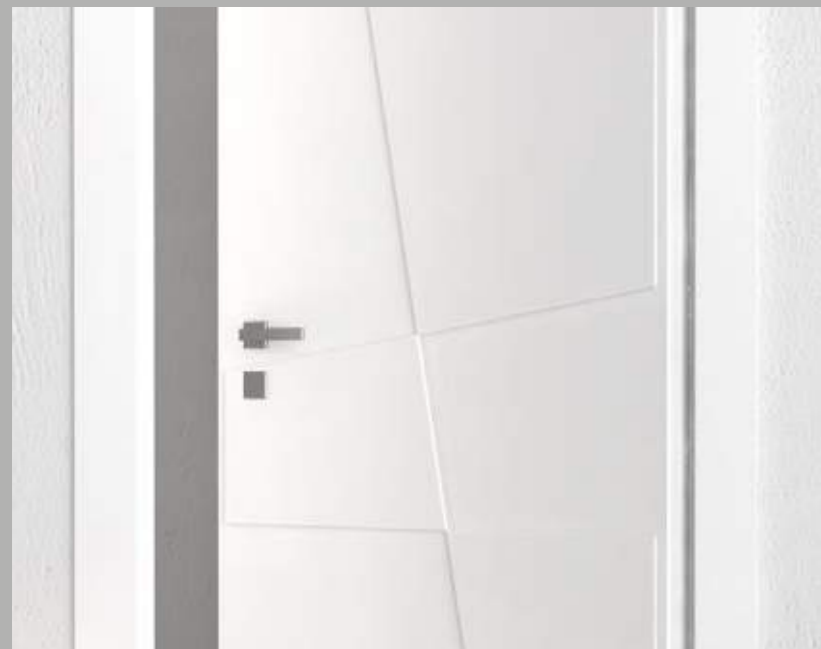

CLIDE



CLIDE

PRESTIGE Easy/Lama Pantografate Cieco

PANTOGRAPHED EASY/LAMA BLIND VERSION
PANTOGRAPHES EASY/LAMA VERSION AVEUGLE



SALINA - P
EASY/LAMA



ELBA - P
EASY/LAMA



CAPRI - P
EASY/LAMA



LAMPIONE - P
EASY/LAMA



VENTOTENE - P
EASY/LAMA



MONTECRISTO - P
EASY/LAMA



CALLIOPE - P
EASY/LAMA



ALANA - P
EASY/LAMA



NOBILIA - P
EASY/LAMA

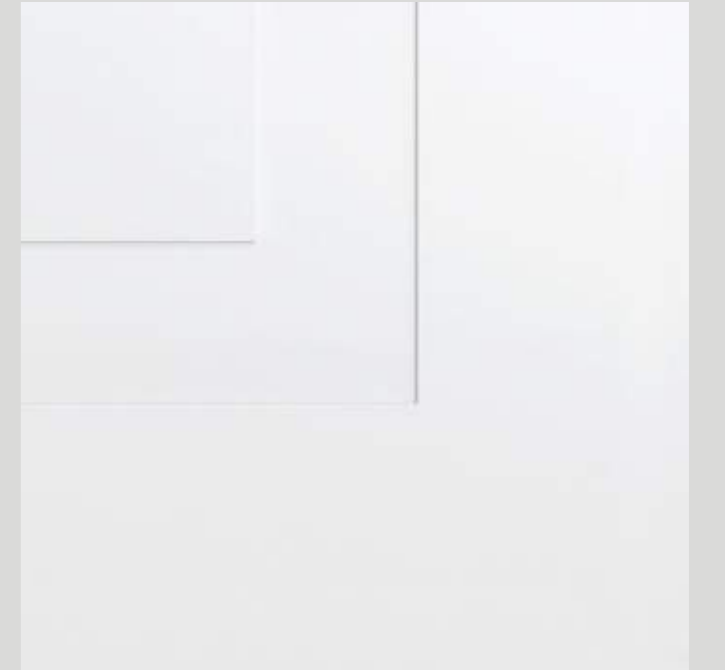

PARTICOLARE EASY PANTOGRAFATE
EASY PANTOGRAPHED DETAIL
DÉTAIL EASY PANTOGRAPHES



KALISA - P
EASY/LAMA



LINOSA - P
EASY/LAMA



GORGONA - P
EASY/LAMA



LA MADDALENA - P
EASY/LAMA



LIPARI - P
EASY/LAMA



SARDEGNA - P
EASY/LAMA



PANTELLERIA - P
EASY/LAMA



TORCELLO - P
EASY/LAMA



GIGLIO - P
EASY/LAMA

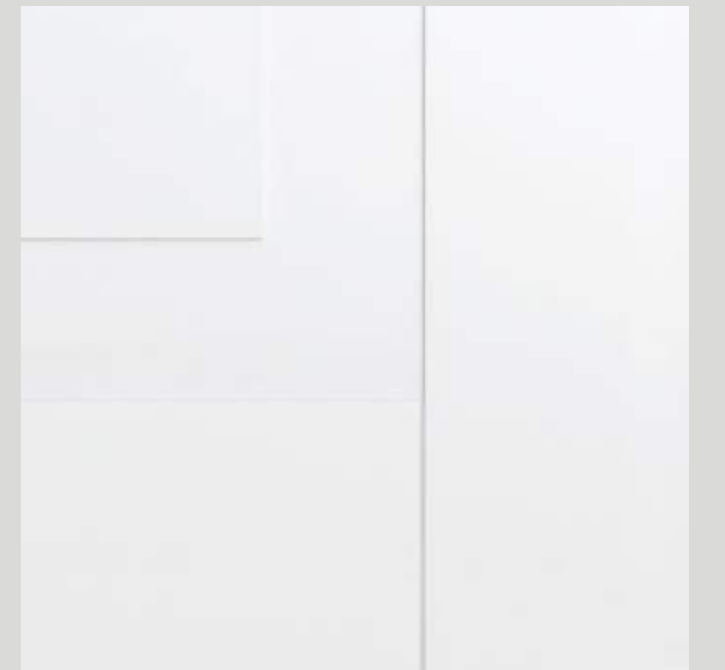

PARTICOLARE LAMA PANTOGRAFATE
LAMA PANTOGRAPHED DETAIL
DÉTAIL LAMA PANTOGRAPHES

PRESTIGE Easy/Lama Pantografate Vetro

PANTOGRAPHED EASY/LAMA GLASS VERSION
EASY/LAMA PANTOGRAPHES VERSION POUR VITRE



SALINA-V
EASY/LAMA



ELBA-V
EASY/LAMA



CAPRI-V
EASY/LAMA



LAMPIONE-V
EASY/LAMA



VENTOTENE-V
EASY/LAMA



MONTECRISTO-V
EASY/LAMA



CALLIOPE-V
EASY/LAMA



ALANA-V
EASY/LAMA



KALISA-V
EASY/LAMA



LINOSA-V
EASY/LAMA



GORGONA-V
EASY/LAMA



LA MADDALENA-V
EASY/LAMA



LIPARI-V
EASY/LAMA



SARDEGNA-V
EASY/LAMA



PANTELLERIA-V
EASY/LAMA



TORCELLO-V
EASY/LAMA



GIGLIO-V
EASY/LAMA

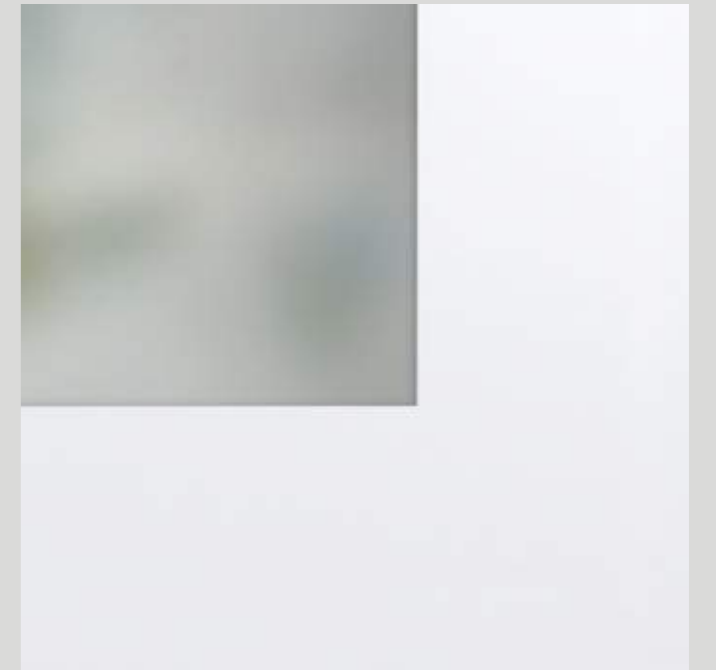

PARTICOLARE EASY PANTOGRAFATE CON VETRO
EASY PANTOGRAPHED WITH GLASS DETAIL
DÉTAIL EASY PANTOGRAPHES VITRÉ

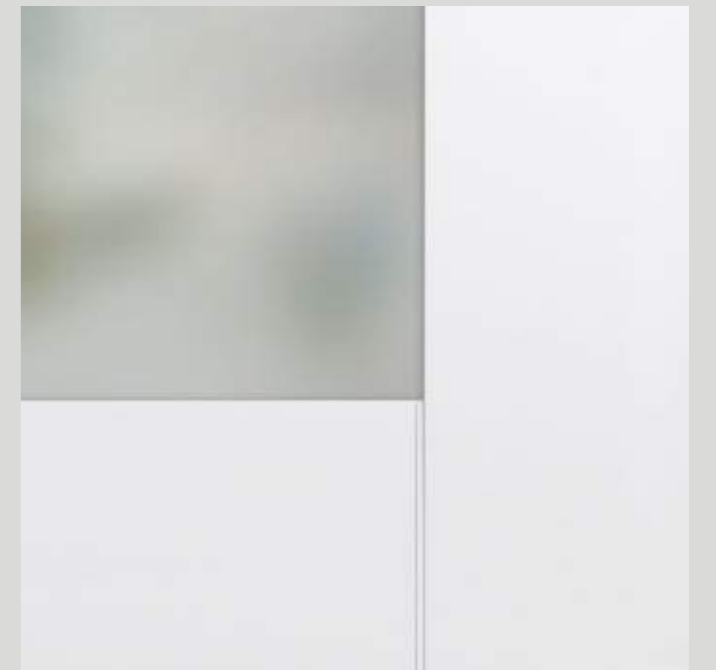

PARTICOLARE LAMA PANTOGRAFATE CON VETRO
LAMA PANTOGRAPHED WITH GLASS DETAIL
DÉTAIL LAMA PANTOGRAPHES VITRÉ



TRASPARENTE
BIANCO

TRASPARENTE
BRONZO

TRASPARENTE
FUMÈ

SATINATO
BIANCO

SATINATO
BRONZO

SATINATO
FUMÈ

SPECCHIO
2 LATI

PRESTIGE Easy/Lama Pantografate Inglese

PANTOGRAPHED EASY/LAMA ENGLISH VERSION
EASY/LAMA PANTOGRAPHES VERSION ANGLAISE



SALINA-I
EASY/LAMA



ELBA-I
EASY/LAMA



LINOSA-I
EASY/LAMA



GORGONA-I
EASY/LAMA



LA MADDALENA-I
EASY/LAMA



LIPARI-I
EASY/LAMA



PANTELLERIA-I
EASY/LAMA



GIGLIO-I
EASY/LAMA



TORCELLO-I
EASY/LAMA



TRASPARENTE
BIANCO



TRASPARENTE
BRONZO



TRASPARENTE
FUMÈ



SATINATO
BIANCO

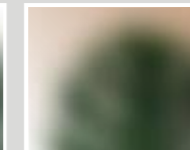

SATINATO
BRONZO

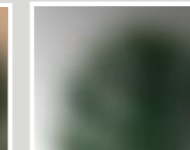

SATINATO
FUMÈ

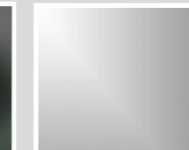

SPECCHIO
2 LATI

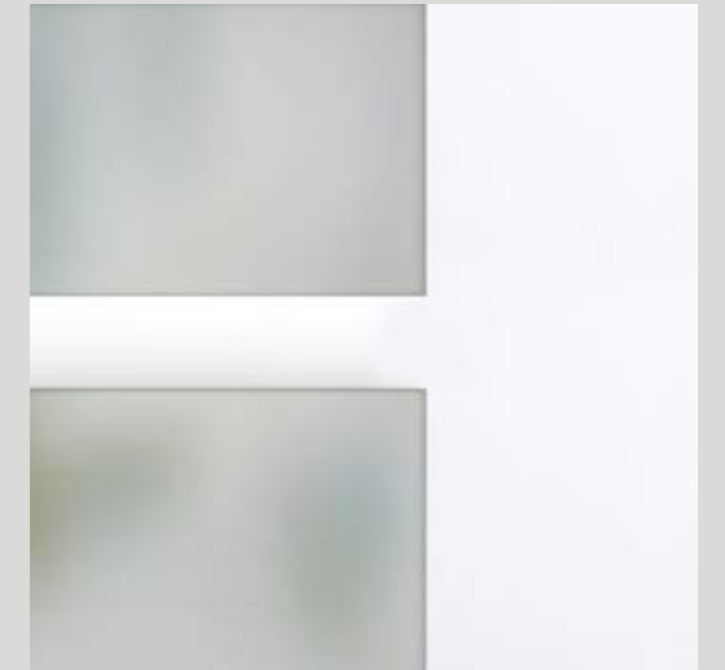

PARTICOLARE EASY PANTOGRAFATE INGLESE
EASY PANTOGRAPHED ENGLISH VERSION DETAIL
DÉTAIL EASY PANTOGRAPHES VERSION ANGLAISE

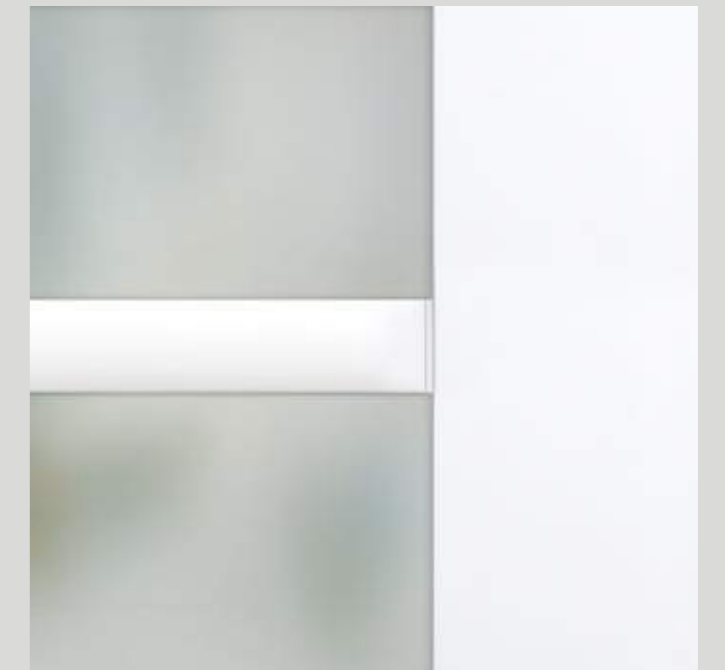

PARTICOLARE LAMA PANTOGRAFATE INGLESE
LAMA PANTOGRAPHED ENGLISH VERSION DETAIL
DÉTAIL LAMA PANTOGRAPHES VERSION ANGLAISE

PRESTIGE Melia/Filea Pantografate Cieco

PANTOGRAPHED MELIA/FILEA BLIND VERSION
PANTOGRAPHES MELIA/FILEA VERSION AVEUGLE



SALINA - P
MELIA/FILEA



ELBA - P
MELIA/FILEA



CAPRI - P
MELIA/FILEA



LAMPIONE - P
MELIA/FILEA



VENTOTENE - P
MELIA/FILEA



MONTECRISTO - P
MELIA/FILEA



CALLIOPE - P
MELIA/FILEA



ALANA - P
MELIA/FILEA



NOBILIA - P
MELIA/FILEA



PARTICOLARE MELIA PANTOGRAFATE
MELIA PANTOGRAPHED DETAIL
DÉTAIL MELIA PANTOGRAPHES



KALISA - P
MELIA/FILEA



LINOSA - P
MELIA/FILEA



GORGONA - P
MELIA/FILEA



LA MADDALENA - P
MELIA/FILEA



LIPARI - P
MELIA/FILEA



SARDEGNA - P
MELIA/FILEA



PANTELLERIA - P
MELIA/FILEA



TORCELLO - P
MELIA/FILEA



GIGLIO - P
MELIA/FILEA



PARTICOLARE FILEA PANTOGRAFATE
FILEA PANTOGRAPHED DETAIL
DÉTAIL FILEA PANTOGRAPHES

PRESTIGE Melia/Filea Pantografate Vetro

PANTOGRAPHED MELIA/FILEA GLASS VERSION
MELIA/FILEA PANTOGRAPHES VERSION POUR VITRE



SALINA-V
MELIA/FILEA



ELBA-V
MELIA/FILEA



CAPRI-V
MELIA/FILEA



LAMPIONE-V
MELIA/FILEA



VENTOTENE-V
MELIA/FILEA



MONTECRISTO-V
MELIA/FILEA



CALLIOPE-V
MELIA/FILEA



ALANA-V
MELIA/FILEA



KALISA-V
MELIA/FILEA



LINOSA-V
MELIA/FILEA



GORGONA-V
MELIA/FILEA



LA MADDALENA-V
MELIA/FILEA



LIPARI-V
MELIA/FILEA



SARDEGNA-V
MELIA/FILEA



PANTELLERIA-V
MELIA/FILEA



TORCELLO-V
MELIA/FILEA



GIGLIO-V
MELIA/FILEA

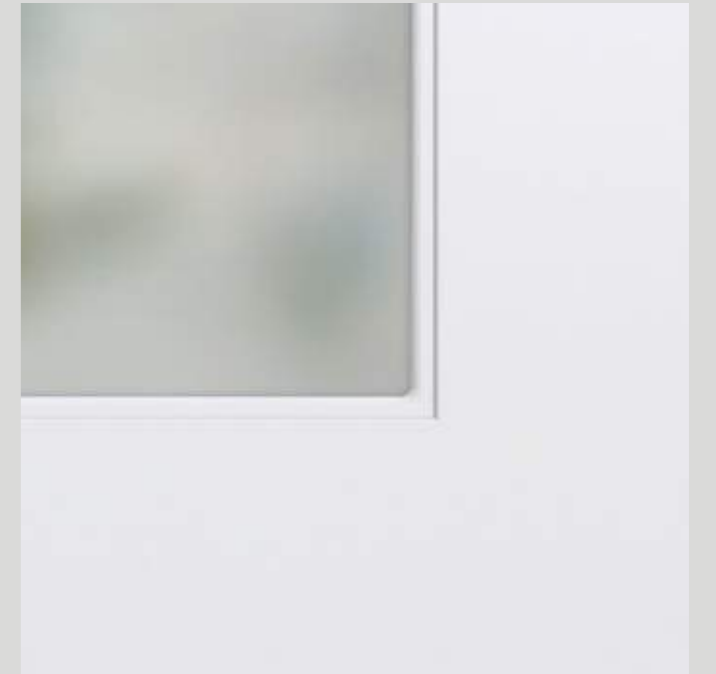

PARTICOLARE MELIA PANTOGRAFATE CON VETRO
MELIA PANTOGRAPHED WITH GLASS DETAIL
DÉTAIL MELIA PANTOGRAPHES VITRÉ

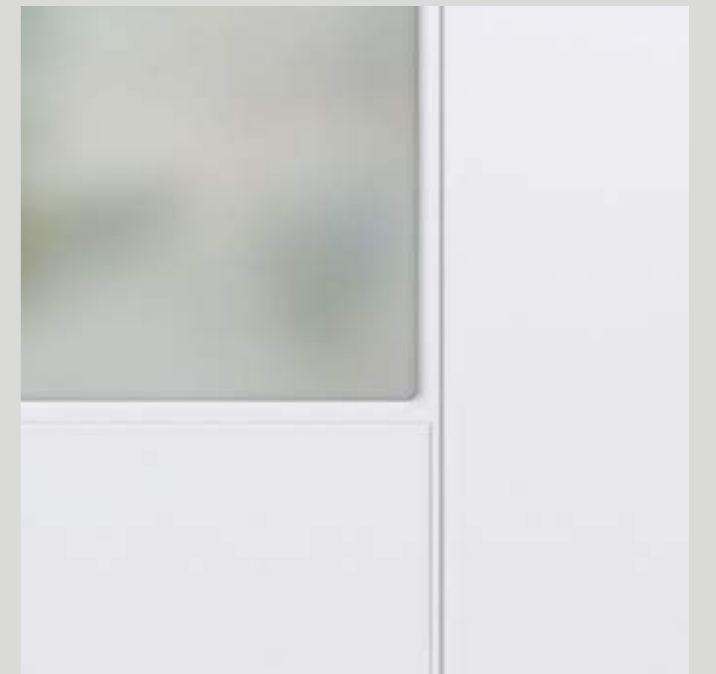

PARTICOLARE FILEA PANTOGRAFATE CON VETRO
FILEA PANTOGRAPHED WITH GLASS DETAIL
DÉTAIL FILEA PANTOGRAPHES VITRÉ



TRASPARENTE
BIANCO

TRASPARENTE
BRONZO

TRASPARENTE
FUMÉ

SATINATO
BIANCO

SATINATO
BRONZO

SATINATO
FUMÉ

SPECCHIO
2 LATI

PRESTIGE Melia/Filea Pantografate Inglese

PANTOGRAPHED MELIA/FILEA ENGLISH VERSION
MELIA/FILEA PANTOGRAPHES VERSION ANGLAISE



SALINA-I
MELIA/FILEA



ELBA-I
MELIA/FILEA



LINOSA-I
MELIA/FILEA



GORGONA-I
MELIA/FILEA



LA MADDALENA-I
MELIA/FILEA



LIPARI-I
MELIA/FILEA



PANTELLERIA-I
MELIA/FILEA



TORCELLO-I
MELIA/FILEA



GIGLIO-I
MELIA/FILEA



TRASPARENTE
BIANCO

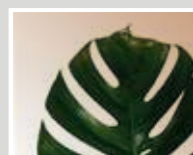

TRASPARENTE
BRONZO



TRASPARENTE
FUMÈ



SATINATO
BIANCO

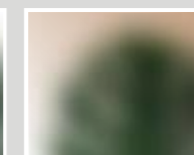

SATINATO
BRONZO

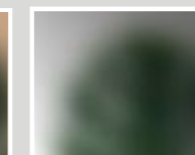

SATINATO
FUMÈ

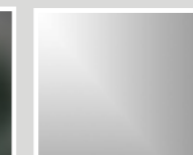

SPECCHIO
2 LATI

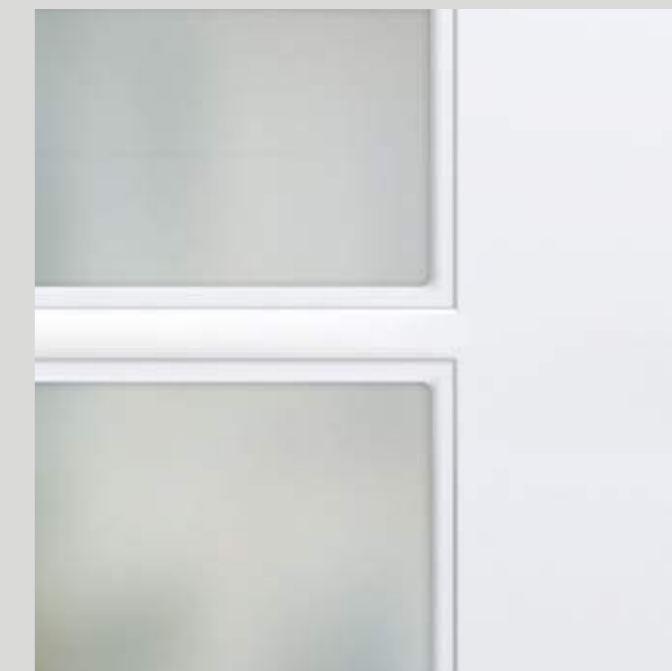

PARTICOLARE MELIA PANTOGRAFATE INGLESE
MELIA PANTOGRAPHED ENGLISH VERSION DETAIL
DÉTAIL MELIA PANTOGRAPHES VERSION ANGLAISE

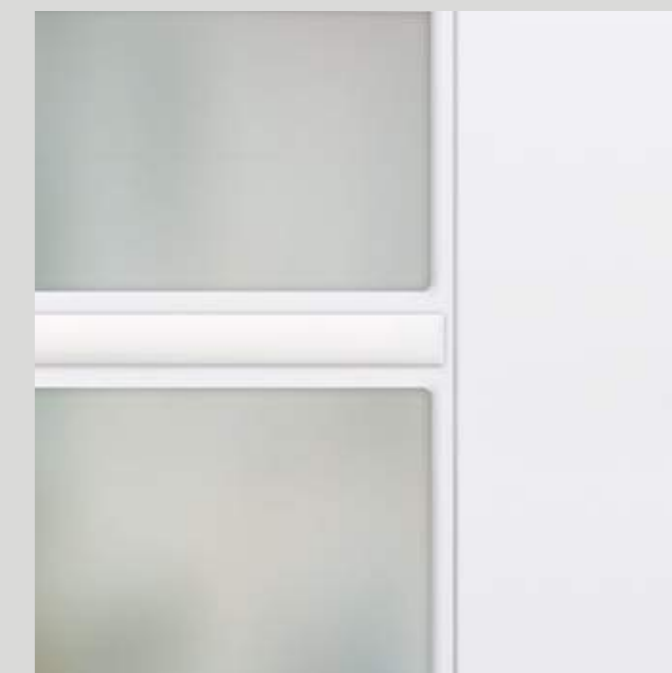

PARTICOLARE FILEA PANTOGRAFATE INGLESE
FILEA PANTOGRAPHED ENGLISH VERSION DETAIL
DÉTAIL FILEA PANTOGRAPHES VERSION ANGLAISE

PRESTIGE Diagon/Traver Pantografate Cieco

PANTOGRAPHED DIAGON / TRAVER BLIND VERSION
PANTOGRAPHES DIAGON / TRAVER VERSION AVEUGLE



SALINA - P
DIAGON / TRAVER



ELBA - P
DIAGON / TRAVER



CAPRI - P
DIAGON / TRAVER



LAMPIONE - P
DIAGON / TRAVER



VENTOTENE - P
DIAGON / TRAVER



MONTECRISTO - P
DIAGON / TRAVER



CALLIOPE - P
DIAGON / TRAVER



ALANA - P
DIAGON / TRAVER



NOBILIA - P
DIAGON / TRAVER



PARTICOLARE DIAGON PANTOGRAFATE
DIAGON PANTOGRAPHED DETAIL
DÉTAIL DIAGON PANTOGRAPHES



KALISA - P
DIAGON / TRAVER



LINOSA - P
DIAGON / TRAVER



GORGONA - P
DIAGON / TRAVER



LA MADDALENA - P
DIAGON / TRAVER



LIPARI - P
DIAGON / TRAVER



SARDEGNA - P
DIAGON / TRAVER



PANTELLERIA - P
DIAGON / TRAVER



TORCELLO - P
DIAGON / TRAVER



GIGLIO - P
DIAGON / TRAVER



PARTICOLARE TRAVER PANTOGRAFATE
TRAVER PANTOGRAPHED DETAIL
DÉTAIL TRAVER PANTOGRAPHES

PRESTIGE Diagon/Traver Pantografate Vetro

PANTOGRAPHED DIAGON/TRAVER GLASS VERSION
DIAGON/TRAVER PANTOGRAPHES VERSION POUR VITRE



SALINA-V
DIAGON/TRAVER



ELBA-V
DIAGON/TRAVER



CAPRI-V
DIAGON/TRAVER



LAMPIONE-V
DIAGON/TRAVER



VENTOTENE-V
DIAGON/TRAVER



MONTECRISTO-V
DIAGON/TRAVER



CALLIOPE-V
DIAGON/TRAVER



ALANA-V
DIAGON/TRAVER



KALISA-V
DIAGON/TRAVER



LINOSA-V
DIAGON/TRAVER



GORGONA-V
DIAGON/TRAVER



LA MADDALENA-V
DIAGON/TRAVER



LIPARI-V
DIAGON/TRAVER



SARDEGNA-V
DIAGON/TRAVER



PANTELLERIA-V
DIAGON/TRAVER



TORCELLO-V
DIAGON/TRAVER



GILGIO-V
DIAGON/TRAVER

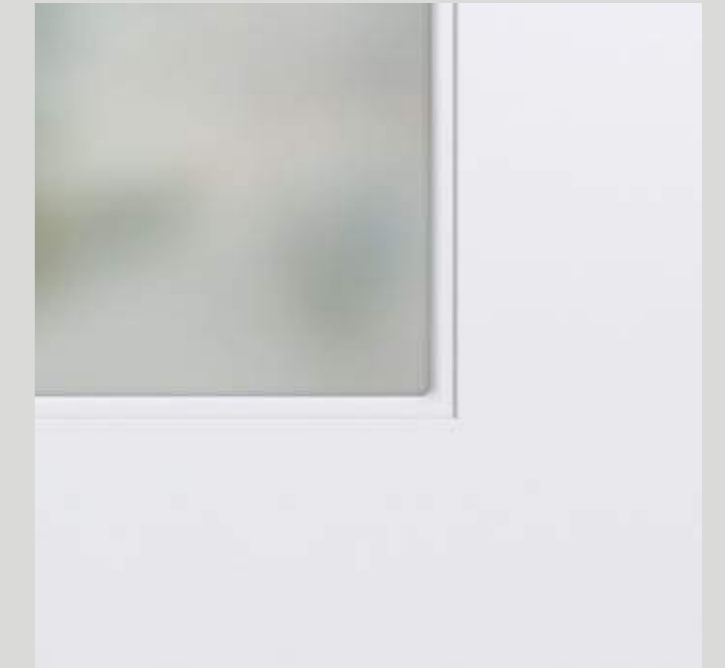

PARTICOLARE DIAGON PANTOGRAFATE CON VETRO
DIAGON PANTOGRAPHED WITH GLASS DETAIL
DÉTAIL DIAGON PANTOGRAPHES VITRÉ

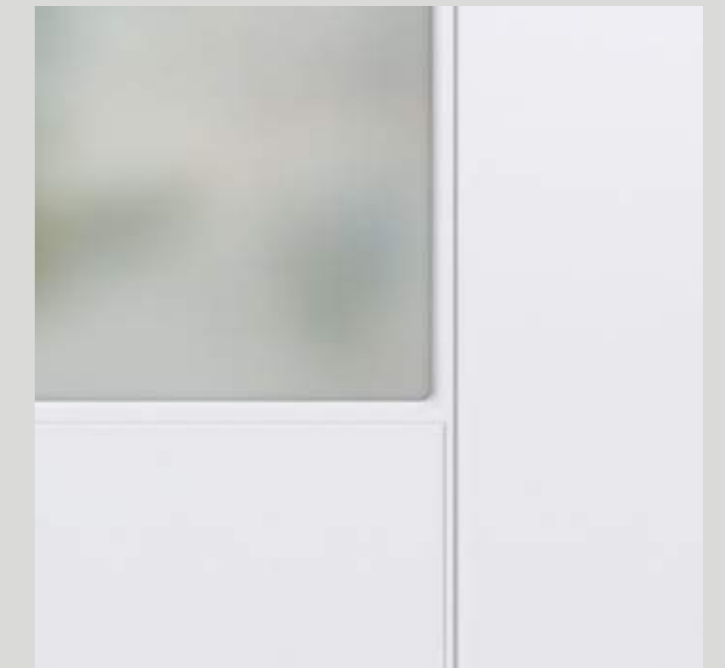

PARTICOLARE TRAVER PANTOGRAFATE CON VETRO
TRAVER PANTOGRAPHED WITH GLASS DETAIL
DÉTAIL TRAVER PANTOGRAPHES VITRÉ



TRASPARENTE
BIANCO

TRASPARENTE
BRONZO

TRASPARENTE
FUMÉ

SATINATO
BIANCO

SATINATO
BRONZO

SATINATO
FUMÉ

SPECCHIO
2 LATI

PRESTIGE Diagon/Traver Pantografate Inglese

PANTOGRAPHED DIAGON/TRAVER ENGLISH VERSION
DIAGON/TRAVER PANTOGRAPHES VERSION ANGLAISE



SALINA-I
DIAGON/TRAVER



ELBA-I
DIAGON/TRAVER



LINOSA-I
DIAGON/TRAVER



GORGONA-I
DIAGON/TRAVER



LA MADDALENA-I
DIAGON/TRAVER



LIPARI-I
DIAGON/TRAVER



PANTELLERIA-I
DIAGON/TRAVER



TORCELLO-I
DIAGON/TRAVER



GIGLIO-I
DIAGON/TRAVER



TRASPARENTE
BIANCO

TRASPARENTE
BRONZO

TRASPARENTE
FUMÈ

SATINATO
BIANCO

SATINATO
BRONZO

SATINATO
FUMÈ

SPECCHIO
2 LATI



PARTICOLARE DIAGON PANTOGRAFATE INGLESE
DIAGON PANTOGRAPHED ENGLISH VERSION DETAIL
DÉTAIL DIAGON PANTOGRAPHES VERSION ANGLAISE

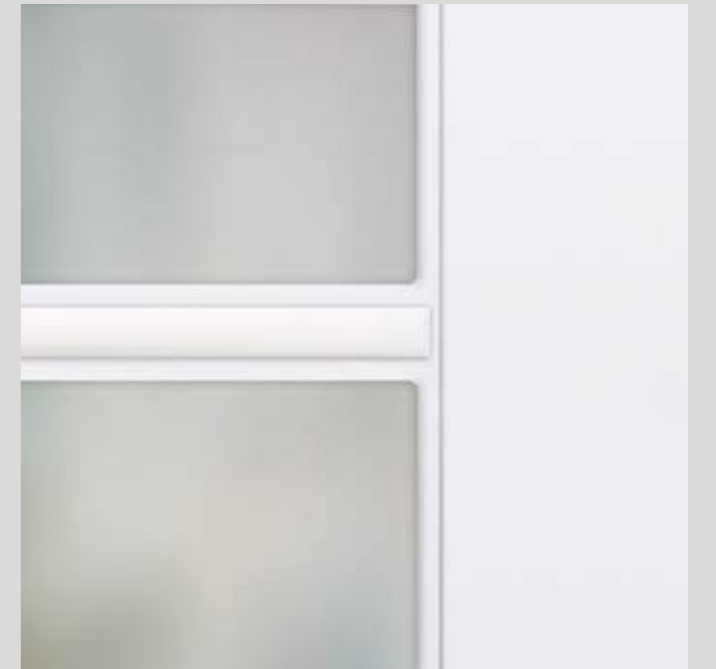

PARTICOLARE TRAVER PANTOGRAFATE INGLESE
TRAVER PANTOGRAPHED ENGLISH VERSION DETAIL
DÉTAIL TRAVER PANTOGRAPHES VERSION ANGLAISE

PRESTIGE Plus/Deco Pantografate Cieco

PANTOGRAPHED PLUS/DECO BLIND VERSION
PANTOGRAPHES PLUS/DECO VERSION AVEUGLE



SALINA - P
PLUS/DECO



ELBA - P
PLUS/DECO



CAPRI - P
PLUS/DECO



LAMPIONE - P
PLUS/DECO



VENTOTENE - P
PLUS/DECO



MONTECRISTO - P
PLUS/DECO



CALLIOPE - P
PLUS/DECO



ALANA - P
PLUS/DECO



NOBILIA - P
PLUS/DECO



PARTICOLARE PLUS PANTOGRAFATE
PLUS PANTOGRAPHED DETAIL
DÉTAIL PLUS PANTOGRAPHES



KALISA - P
PLUS/DECO



LINOSA - P
PLUS/DECO



GORGONA - P
PLUS/DECO



LA MADDALENA - P
PLUS/DECO



LIPARI - P
PLUS/DECO



SARDEGNA - P
PLUS/DECO



PANTELLERIA - P
PLUS/DECO



TORCELLO - P
PLUS/DECO



GIGLIO - P
PLUS/DECO



PARTICOLARE DECO PANTOGRAFATE
DECO PANTOGRAPHED DETAIL
DÉTAIL DECO PANTOGRAPHES

PRESTIGE Plus/Deco Pantografate Vetro

PANTOGRAPHED PLUS/DECO GLASS VERSION
PLUS/DECO PANTOGRAPHES VERSION POUR VITRE



SALINA - V
PLUS/DECO



ELBA - V
PLUS/DECO



CAPRI - V
PLUS/DECO



LAMPIONE - V
PLUS/DECO



VENTOTENE - V
PLUS/DECO



MONTECRISTO - V
PLUS/DECO



CALLIOPE - V
PLUS/DECO



ALANA - V
PLUS/DECO



KALISA - V
PLUS/DECO



LINOSA - V
PLUS/DECO



GORGONA - V
PLUS/DECO



LA MADDALENA - V
PLUS/DECO



LIPARI - V
PLUS/DECO



SARDEGNA - V
PLUS/DECO



PANTELLERIA - V
PLUS/DECO



TORCELLO - V
PLUS/DECO



GIGLIO - V
PLUS/DECO

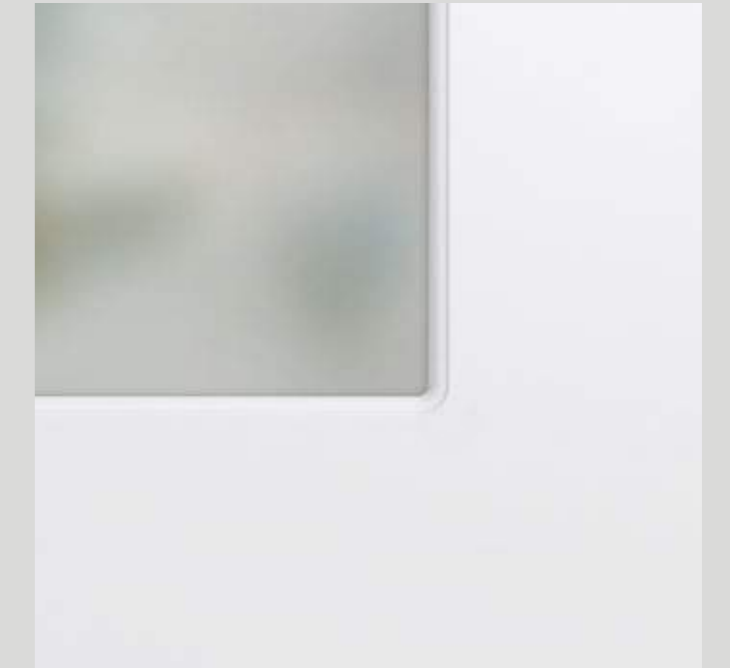

PARTICOLARE PLUS PANTOGRAFATE CON VETRO
PLUS PANTOGRAPHED GLASS VERSION DETAIL
DÉTAIL PLUS PANTOGRAPHES VERSION POUR VITRE

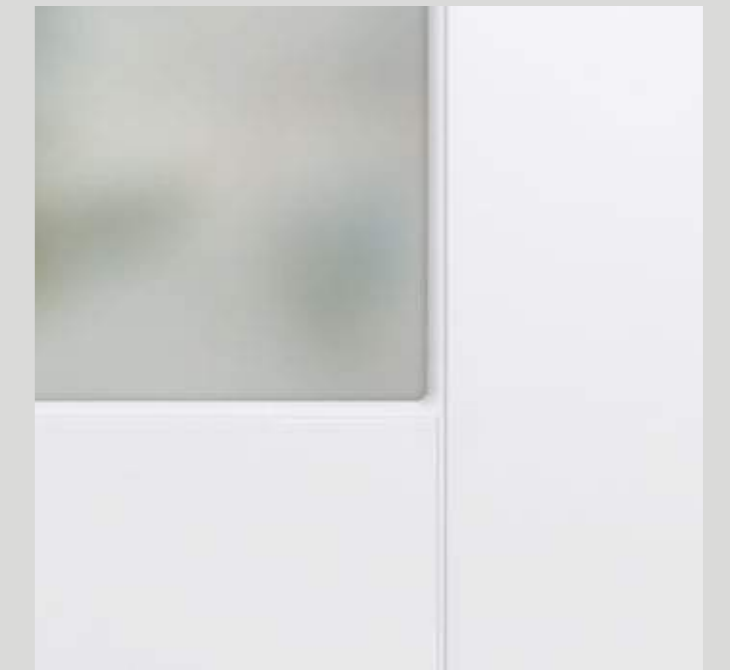

PARTICOLARE DECO PANTOGRAFATE CON VETRO
DECO PANTOGRAPHED GLASS VERSION DETAIL
DÉTAIL DECO PANTOGRAPHES VERSION POUR VITRE



TRASPARENTE
BIANCO

TRASPARENTE
BRONZO

TRASPARENTE
FUMÉ

SATINATO
BIANCO

SATINATO
BRONZO

SATINATO
FUMÉ

SPECCHIO
2 LATI

PRESTIGE Plus/Deco Pantografate Inglese

PANTOGRAPHED PLUS/DECO ENGLISH VERSION
PLUS/DECO PANTOGRAPHES VERSION ANGLAISE



SALINA - I
PLUS/DECO



ELBA - I
PLUS/DECO



LINOSA - I
PLUS/DECO



GORGONA - I
PLUS/DECO



LA MADDALENA - I
PLUS/DECO



LIPARI - I
PLUS/DECO



PANTELLERIA - I
PLUS/DECO



TORCELLO - I
PLUS/DECO



GIGLIO - I
PLUS/DECO



PARTICOLARE PLUS PANTOGRAFATE INGLESE
PLUS PANTOGRAPHED ENGLISH VERSION DETAIL
DÉTAIL PLUS PANTOGRAPHES VERSION ANGLAISE

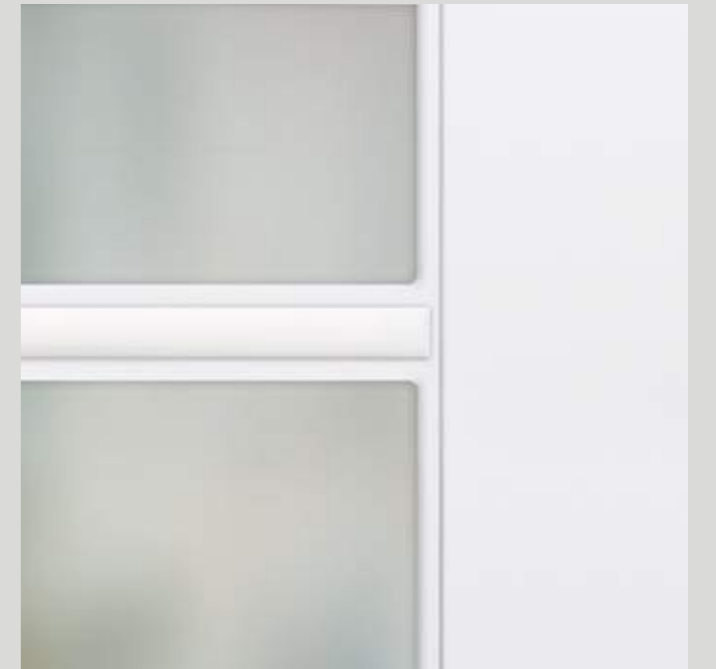

PARTICOLARE DECO PANTOGRAFATE INGLESE
DECO PANTOGRAPHED ENGLISH VERSION DETAIL
DÉTAIL DECO PANTOGRAPHES VERSION ANGLAISE



TRASPARENTE
BIANCO

TRASPARENTE
BRONZO

TRASPARENTE
FUMÉ

SATINATO
BIANCO

SATINATO
BRONZO

SATINATO
FUMÉ

SPECCHIO
2 LATI

PRESTIGE Pregiata/Ornata Pantografate Cieco

PANTOGRAPHED PREGIATA/ORNATA BLIND VERSION
PANTOGRAPHES PREGIATA/ORNATA VERSION AVEUGLE



SALINA - P
PREGIATA/ORNATA



ELBA - P
PREGIATA/ORNATA



CAPRI - P
PREGIATA/ORNATA



LAMPIONE - P
PREGIATA/ORNATA



VENTOTENE - P
PREGIATA/ORNATA



MONTECRISTO - P
PREGIATA/ORNATA



CALLIOPE - P
PREGIATA/ORNATA



ALANA - P
PREGIATA/ORNATA



NOBILIA - P
PREGIATA/ORNATA



PARTICOLARE PREGIATA PANTOGRAFATE
PREGIATA PANTOGRAPHED DETAIL
DÉTAIL PREGIATA PANTOGRAPHES



KALISA - P
PREGIATA/ORNATA



LINOSA - P
PREGIATA/ORNATA



GORGONA - P
PREGIATA/ORNATA



LA MADDALENA - P
PREGIATA/ORNATA



LIPARI - P
PREGIATA/ORNATA



SARDEGNA - P
PREGIATA/ORNATA



PANTELLERIA - P
PREGIATA/ORNATA



TORCELLO - P
PREGIATA/ORNATA



GIGLIO - P
PREGIATA/ORNATA



PARTICOLARE ORNATA PANTOGRAFATE
ORNATA PANTOGRAPHED DETAIL
DÉTAIL ORNATA PANTOGRAPHES

PRESTIGE Pregiata/Ornata Pantografate Vetro

PANTOGRAPHED PREGIATA/ORNATA GLASS VERSION
PREGIATA/ORNATA PANTOGRAPHES VERSION POUR VITRE



SALINA - V
PREGIATA/ORNATA



ELBA - V
PREGIATA/ORNATA



CAPRI - V
PREGIATA/ORNATA



LAMPIONE - V
PREGIATA/ORNATA



VENTOTENE - V
PREGIATA/ORNATA



MONTECRISTO - V
PREGIATA/ORNATA



CALLIOPE - V
PREGIATA/ORNATA



ALANA - V
PREGIATA/ORNATA



KALISA - V
PREGIATA/ORNATA



LINOSA - V
PREGIATA/ORNATA



GORGONA - V
PREGIATA/ORNATA



LA MADDALENA - V
PREGIATA/ORNATA



LIPARI - V
PREGIATA/ORNATA



SARDEGNA - V
PREGIATA/ORNATA



PANTELLERIA - V
PREGIATA/ORNATA



TORCELLO - V
PREGIATA/ORNATA



GIGLIO - V
PREGIATA/ORNATA

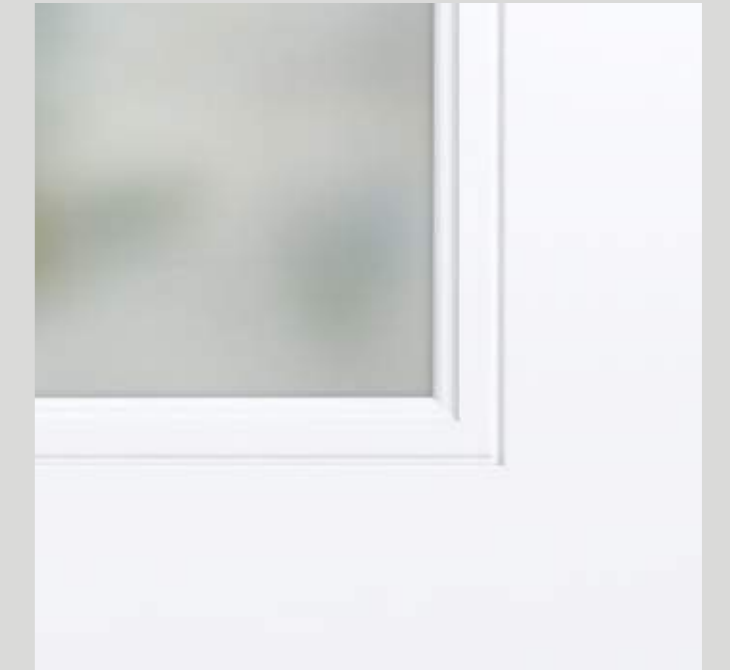

PARTICOLARE PREGIATA PANTOGRAFATE CON VETRO
PREGIATA PANTOGRAPHED WITH GLASS DETAIL
DÉTAIL PREGIATA PANTOGRAPHES VITRÉ

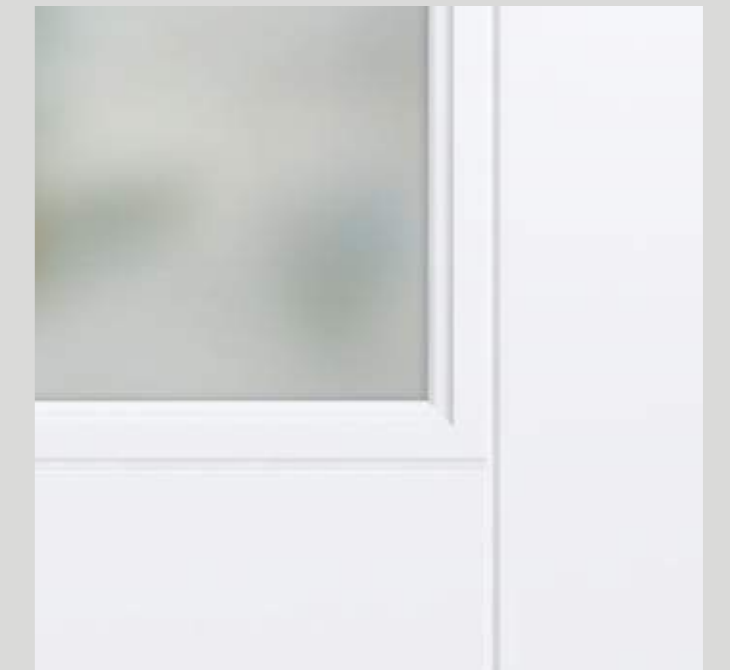

PARTICOLARE ORNATA PANTOGRAFATE CON VETRO
ORNATA PANTOGRAPHED WITH GLASS DETAIL
DÉTAIL ORNATA PANTOGRAPHES VITRÉ



TRASPARENTE
BIANCO

TRASPARENTE
BRONZO

TRASPARENTE
FUMÉ

SATINATO
BIANCO

SATINATO
BRONZO

SATINATO
FUMÉ

SPECCHIO
2 LATI

PRESTIGE Pregiata/Ornata Pantografate Inglese

PANTOGRAPHED PREGIATA/ORNATA ENGLISH VERSION
PREGIATA/ORNATA PANTOGRAPHES VERSION ANGLAISE



SALINA-I
PREGIATA/ORNATA



ELBA-I
PREGIATA/ORNATA



LINOSA-I
PREGIATA/ORNATA



GORGONA-I
PREGIATA/ORNATA



LA MADDALENA-I
PREGIATA/ORNATA



LIPARI-I
PREGIATA/ORNATA



PANTELLERIA-I
PREGIATA/ORNATA



TORCELLO-I
PREGIATA/ORNATA



GIGLIO-I
PREGIATA/ORNATA



PARTICOLARE PREGIATA PANTOGRAFATE INGLESE
PREGIATA PANTOGRAPHED ENGLISH VERSION DETAIL
DÉTAIL PREGIATA PANTOGRAPHES VERSION ANGLAISE

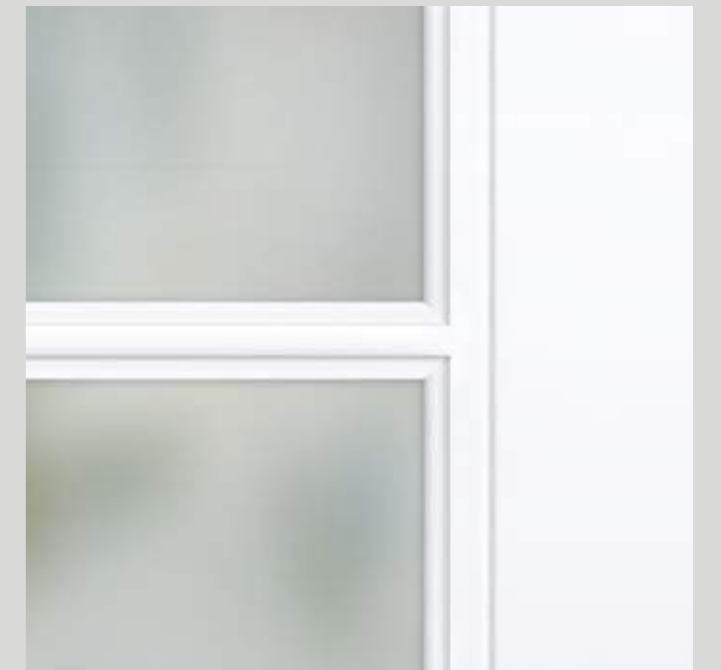

PARTICOLARE ORNATA PANTOGRAFATE INGLESE
ORNATA PANTOGRAPHED ENGLISH VERSION DETAIL
DÉTAIL ORNATA PANTOGRAPHES VERSION ANGLAISE



TRASPARENTE
BIANCO

TRASPARENTE
BRONZO

TRASPARENTE
FUMÉ

SATINATO
BIANCO

SATINATO
BRONZO

SATINATO
FUMÉ

SPECCHIO
2 LATI

PRESTIGE Evoluta Pantografate Cieco

PANTOGRAPHED EVOLUTA BLIND VERSION
PANTOGRAPHES EVOLUTA VERSION AVEUGLE



SALINA - P
EVOLUTA



ELBA - P
EVOLUTA



CAPRI - P
EVOLUTA



LAMPIONE - P
EVOLUTA



VENTOTENE - P
EVOLUTA



MONTECRISTO - P
EVOLUTA



CALLIOPE - P
EVOLUTA



ALANA - P
EVOLUTA



NOBILIA - P
EVOLUTA

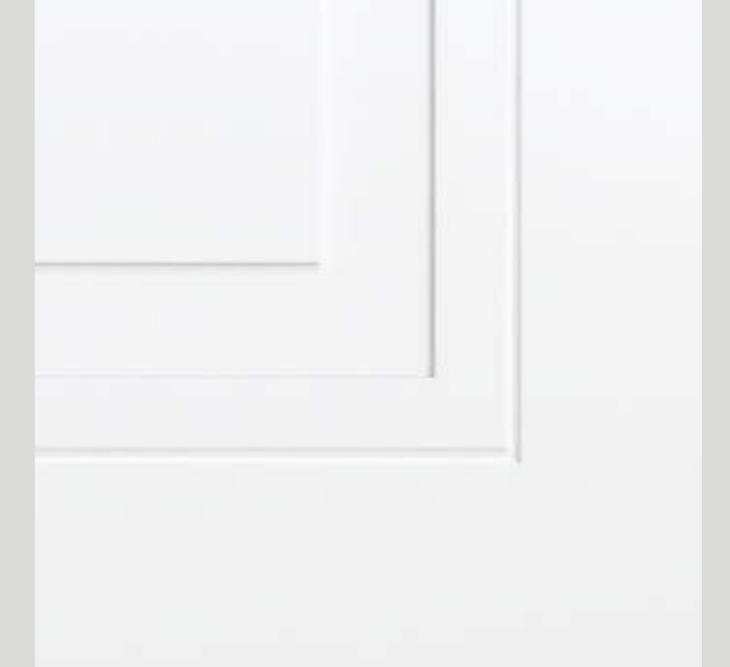

PARTICOLARE EVOLUTA PANTOGRAFATE
EVOLUTA PANTOGRAPHED DETAIL
DÉTAIL EVOLUTA PANTOGRAPHES



KALISA - P
EVOLUTA



LINOSA - P
EVOLUTA



GORGONA - P
EVOLUTA



LA MADDALENA - P
EVOLUTA



LIPARI - P
EVOLUTA



SARDEGNA - P
EVOLUTA



PANTELLERIA - P
EVOLUTA



TORCELLO - P
EVOLUTA



GIGLIO - P
EVOLUTA

PRESTIGE Evoluta Pantografate Vetro

PANTOGRAPHED EVOLUTA GLASS VERSION
EVOLUTA PANTOGRAPHES VERSION POUR VITRE



SALINA - V
EVOLUTA



ELBA - V
EVOLUTA



CAPRI - V
EVOLUTA



LAMPIONE - V
EVOLUTA



VENTOTENE - V
EVOLUTA



MONTECRISTO - V
EVOLUTA



CALLIOPE - V
EVOLUTA



ALANA - V
EVOLUTA

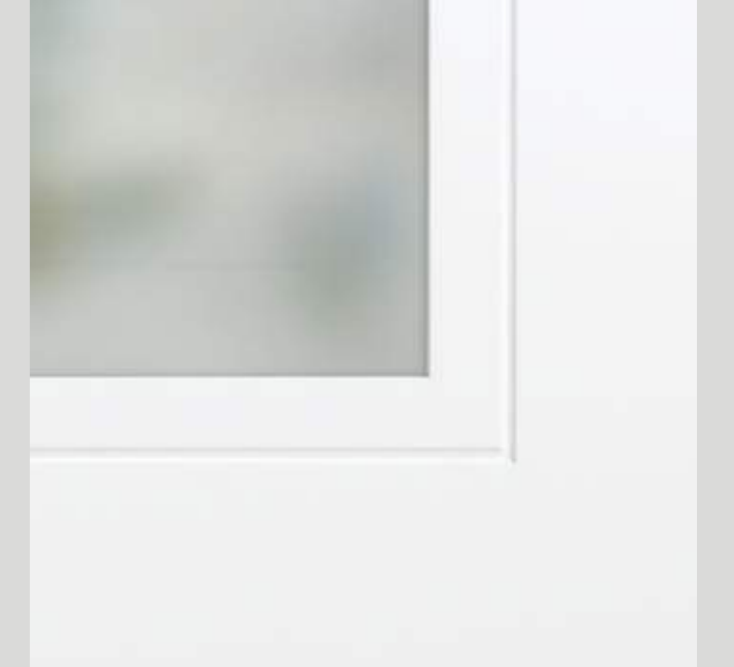

PARTICOLARE EVOLUTA PANTOGRAFATE CON VETRO
EVOLUTA PANTOGRAPHED GLASS VERSION DETAIL
DÉTAIL EVOLUTA PANTOGRAPHES VERSION POUR VITRE



KALISA - V
EVOLUTA



LINOSA - V
EVOLUTA



GORGONA - V
EVOLUTA



LA MADDALENA - V
EVOLUTA



LIPARI - V
EVOLUTA



SARDEGNA - V
EVOLUTA



PANTELLERIA - V
EVOLUTA



TORCELLO - V
EVOLUTA



GIGLIO - V
EVOLUTA



TRASPARENTE
BIANCO

TRASPARENTE
BRONZO

TRASPARENTE
FUMÉ

SATINATO
BIANCO

SATINATO
BRONZO

SATINATO
FUMÉ

SPECCHIO
2 LATI

PRESTIGE Evoluta Pantografate Inglese

PANTOGRAPHED EVOLUTA ENGLISH VERSION
EVOLUTA PANTOGRAPHES VERSION ANGLAISE



SALINA-I
EVOLUTA



ELBA-I
EVOLUTA



LINOSA-I
EVOLUTA



GORGONA-I
EVOLUTA



LA MADDALENA-I
EVOLUTA



LIPARI-I
EVOLUTA



PANTELLERIA-I
EVOLUTA



TORCELLO-I
EVOLUTA



GIGLIO-I
EVOLUTA

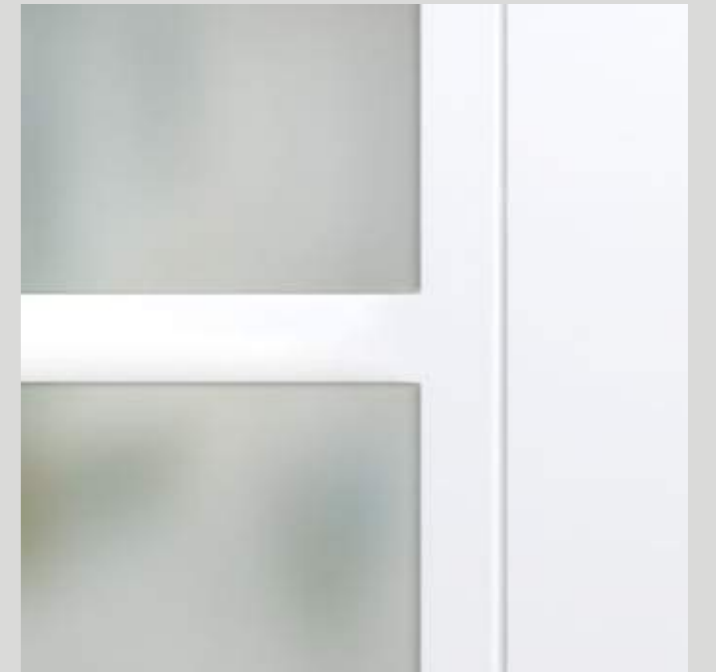

PARTICOLARE EVOLUTA PANTOGRAFATE INGLESE
EVOLUTA PANTOGRAPHED ENGLISH VERSION DETAIL
DÉTAIL EVOLUTA PANTOGRAPHES VERSION ANGLAISE



TRASPARENTE
BIANCO



TRASPARENTE
BRONZO



TRASPARENTE
FUMÈ



SATINATO
BIANCO

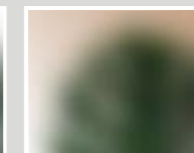

SATINATO
BRONZO

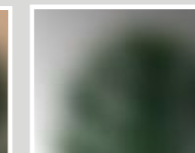

SATINATO
FUMÈ



SPECCHIO
2 LATI

PRESTIGE Decorì per Pantografate - Floreale e Nobile

DECORATION FOR PANTOGRAPHED - FLOREALE AND NOBILE
DÉCORATION POUR PANTOGRAPHES - FLOREALE ET NOBILE



SALINA - P



ELBA - P



CAPRI - P



LAMPIONE - P



MONTECRISTO - P



SARDEGNA - P



PANTELLERIA - P



TORCELLO - P



GIGLIO - P



PARTICOLARE FLOREALE
FLOREALE DETAIL
DÉTAIL FLOREALE



KALISA - P



LINOSA - P



GORGONA - P



LA MADDALENA - P



LIPARI - P



VENTOTENE - P



CALLIOPE - P



ALANA - P



NOBILIA - P

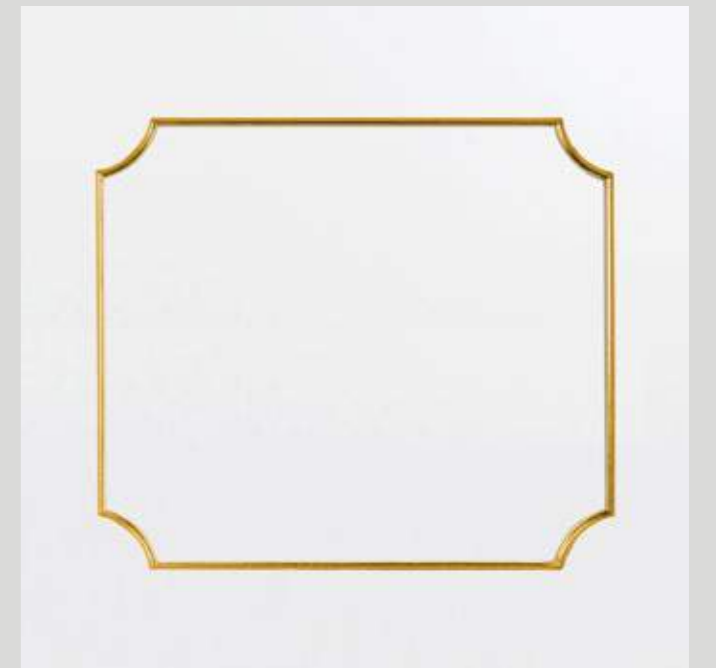

PARTICOLARE NOBILE
NOBILE DETAIL
DÉTAIL NOBILE

I decorì Floreale e Nobile sono realizzabili su tutti i modelli rappresentati

Floreale and Noble decorations are available for all the models represented.

Les décorations Floreale et Noble sont disponibles pour tous les modèles représentés.

PRESTIGE Pantografata Laccato

PANTOGRAPHED LACQUERED
PANTOGRAPHES LAQUÉ



CAPRI-V
MELIA



CAPRI-P
FILEA

PRESTIGE Pantografata Laccato

PANTOGRAPHED LACQUERED
PANTOGRAPHES LAQUÉ



SALINA - P
TRAVER



SALINA - V
DIAGON

PRESTIGE Pantografata Laccato

PANTOGRAPHED LACQUERED
PANTOGRAPHES LAQUÉ



PANTELLERIA-P
DIAGON



PANTELLERIA-V
TRAVER



ELBA-P
MELIA



ELBA-P
FILEA

PRESTIGE
Pantografata Laccato

PANTOGRAPHED LACQUERED
PANTOGRAPHES LAQUÉ



ELBA - V
EASY

ELBA - P
EASY

PRESTIGE Pantografata Laccato

PANTOGRAPHED LACQUERED
PANTOGRAPHES LAQUÉ



MONTECRISTO - P
LAMA



MONTECRISTO - V
EASY



GORGONA - V
MELIA



GORGONA - P
FILEA

PRESTIGE Pantografata Laccato

PANTOGRAPHED LACQUERED
PANTOGRAPHES LAQUÉ



VENTOTENE-V
EASY



VENTOTENE-P
EASY



LAMPIONE-V
DECO



LAMPIONE-P
PLUS

PRESTIGE Pantografata Laccato

PANTOGRAPHED LACQUERED
PANTOGRAPHES LAQUÉ



LINOSA - P
EVOLUTA



LINOSA - I
EVOLUTA



SARDEGNA - V
ORNATA



SARDEGNA - P
ORNATA

PRESTIGE Pantografata Laccato

PANTOGRAPHED LACQUERED
PANTOGRAPHES LAQUÉ



NOBLIA - P
DIAGON

PRESTIGE Pantografata Laccato

PANTOGRAPHED LACQUERED
PANTOGRAPHES LAQUÉ



LA MADDALENA-V
EASY



LA MADDALENA-P
EASY



LIPARI-P
TRAVER



LIPARI-V
DIAGON

PRESTIGE Pantografata Laccato

PANTOGRAPHED LACQUERED
PANTOGRAPHES LAQUÉ



KALISA - V
DIAGON



KALISA - P
TRAVER

PRESTIGE Pantografata Laccato

PANTOGRAPHED LACQUERED
PANTOGRAPHES LAQUÉ



ALANA-P
EASY



ALANA-V
EASY



CALLIOPE-V
EVOLUTA



CALLIOPE-P
MELIA

PRESTIGE
Pantografata Laccato

PANTOGRAPHED LACQUERED
PANTOGRAPHES LAQUÉ



**SARDEGNA - P
ORNATA**
COPRIFILO MODIGLIANI

**CALLIOPE - P
EVOLUTA**
COPRIFILO PICASSO

**KALISA - P
MELIA**
COPRIFILO TINTORETTO - CAPITELLO BRUNELLESCHI

PRESTIGE Pantografata Laccato

PANTOGRAPHED LACQUERED
PANTOGRAPHES LAQUÉ



GIGLIO - I
EVOLUTA



GIGLIO - P
EVOLUTA



GIGLIO - V
EVOLUTA

PRESTIGE Pantografata Laccato

PANTOGRAPHED LACQUERED
PANTOGRAPHES LAQUÉ



TORCELLO - V
PREGIATA



TORCELLO - P
PREGIATA

PRESTIGE 3D Pantografate

PANTOGRAPHED 3D
3D PANTOGRAPHES



SALINA - P
3 D



ELBA - P
3 D



LAMPIONE - P
3 D



CAPRI - P
3 D



KALISA - P
3 D



NOBILIA - P
3 D

PRESTIGE 3D Pantografate Vetro

PANTOGRAPHED 3D GLASS VERSION
3D PANTOGRAPHES VERSION POUR VITRE



SALINA - V
3 D



ELBA - V
3 D



LAMPIONE - V
3 D



CAPRI - V
3 D



KALISA - V
3 D



TRASPARENTE
BIANCO



TRASPARENTE
BRONZO



TRASPARENTE
FUMÈ



SATINATO
BIANCO

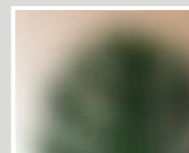

SATINATO
BRONZO



SATINATO
FUMÈ



SPECCHIO
2 LATI



PARTICOLARE 3D PANTOGRAFATE
3D PANTOGRAPHED DETAIL
DÉTAIL 3D PANTOGRAPHES



PARTICOLARE 3D PANTOGRAFATE CON VETRO
3D PANTOGRAPHED WITH GLASS DETAIL
DÉTAIL 3D PANTOGRAPHES VITRÉ

PRESTIGE 3D Pantografata Laccato

PANTOGRAPHED 3D LACQUERED
3D PANTOGRAPHES LAQUÉ



NOBILIA - P
3 D



SALINA - V
3 D



SALINA - P
3 D

PRESTIGE 3D Pantografata Laccato

PANTOGRAPHED 3D LACQUERED
3D PANTOGRAPHES LAQUÉ



ELBA - V
3 D



ELBA - P
3 D

PRESTIGE 3D Pantografata Laccato

PANTOGRAPHED 3D LACQUERED
3D PANTOGRAPHES LAQUÉ



CAPRI-V
3D



CAPRI-P
3D

PRESTIGE 3D Pantografata Laccato

PANTOGRAPHED 3D LACQUERED
3D PANTOGRAPHES LAQUÉ



LAMPIONE - V
3 D



LAMPIONE - P
3 D

PRESTIGE
3D Pantografata Laccato

PANTOGRAPHED 3D LACQUERED
3D PANTOGRAPHES LAQUÉ



KALISA - V
3 D



KALISA - P
3 D

MATERIKA MTK

MATERIKA MTK
MATERIKA MTK



MTK SALINA-P
(EASY-LAMA/MELIA-FILEA/
DIAGON-TRAVER)



MTK ELBA-P
(EASY-LAMA/MELIA-FILEA/
DIAGON-TRAVER)



MTK CAPRI-P
(EASY-LAMA/MELIA-FILEA/
DIAGON-TRAVER)



MTK LAMPIONE-P
(EASY-LAMA/MELIA-FILEA/
DIAGON-TRAVER)

MTK EASY



PARTICOLARE EASY PANTOGRAFATE
EASY PANTOGRAPHED DETAIL
DÉTAIL EASY PANTOGRAPHES

MTK MELIA

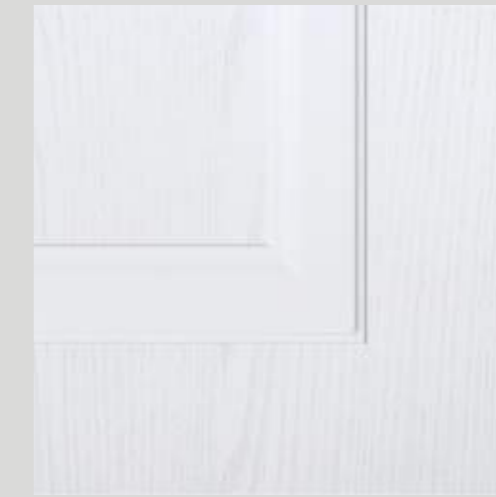

PARTICOLARE MELIA PANTOGRAFATE
MELIA PANTOGRAPHED DETAIL
DÉTAIL MELIA PANTOGRAPHES

MTK DIAGON



PARTICOLARE DIAGON PANTOGRAFATE
DIAGON PANTOGRAPHED DETAIL
DÉTAIL DIAGONPANTOGRAPHES

MATERIKA MTK Vetro

MATERIK MTK WITH GLASS VERSION
MATERIK MTK VERSION POUR VITRE



MTK SALINA-V
(EASY-LAMA/MELIA-FILEA/
DIAGON-TRAVER)



MTK ELBA-V
(EASY-LAMA/MELIA-FILEA/
DIAGON-TRAVER)



MTK CAPRI-V
(EASY-LAMA/MELIA-FILEA/
DIAGON-TRAVER)



MTK LAMPIONE-V
(EASY-LAMA/MELIA-FILEA/
DIAGON-TRAVER)

MTK LAMA

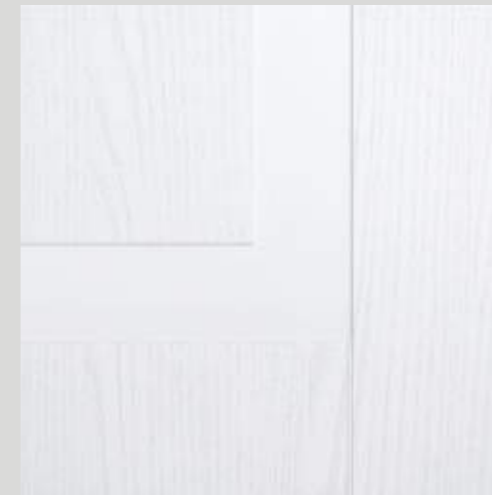

PARTICOLARE LAMA PANTOGRAFATE
LAMA PANTOGRAPHED DETAIL
DÉTAIL LAMA PANTOGRAPHES

MTK FILEA

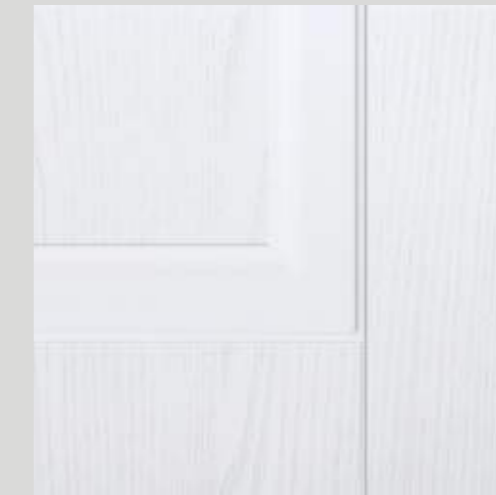

PARTICOLARE FILEA PANTOGRAFATE
FILEA PANTOGRAPHED DETAIL
DÉTAIL FILEA PANTOGRAPHES

MTK TRAVER



PARTICOLARE TRAVER PANTOGRAFATE
TRAVER PANTOGRAPHED DETAIL
DÉTAIL TRAVER PANTOGRAPHES



TRASPARENTE
BIANCO

TRASPARENTE
BRONZO

TRASPARENTE
FUMÉ

SATINATO
BIANCO

SATINATO
BRONZO

SATINATO
FUMÉ

SPECCHIO
2 LATI

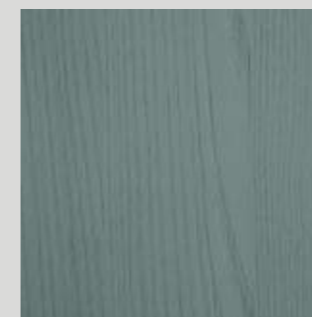

ROVERE VERTICALE LACCATO

MATERIKA MTK

MATERIKA MTK
MATERIKA MTK



MTK*
LAMPIONE - V
DIAGON

*
Porte con telaio e coprifilo LISCIO
Doors with SMOOTH Frame and Casing
Portes avec Cadre et Couvre-joints LISSE



MTK LAMPIONE - P*
DIAGON

MATERIKA MTK

MATERIKA MTK
MATERIKA MTK



MTK SALINA - P*
EASY



MTK ELBA - V*
EASY

*
Porte con telaio e coprifilo LISCIO
Doors with SMOOTH Frame and Casing
Portes avec Cadre et Couvre-joints LISSE



MTK ELBA - P*
EASY

MATERIKA MTK

MATERIKA MTK
MATERIKA MTK



*
Porte con telaio e coprifilo LISCIO
Doors with SMOOTH Frame and Casing
Portes avec Cadre et Couvre-joints LISSE

*MTK CAPRI - P
MELIA

MTK CAPRI - V*
MELIA

LEGGERA Pantografate

PANTOGRAPHED LEGGERA
LEGGERA PANTOGRAPHES



LEGGERA Pantografate Vetro

PANTOGRAPHED LEGGERA GLASS VERSION
LEGGERA PANTOGRAPHES VERSION POUR VITRE



LEGGERA Pantografate Inglese

PANTOGRAPHED LEGGERA GLASS ENGLISH VERSION
LEGGERA PANTOGRAPHES VERSION ANGLAISE

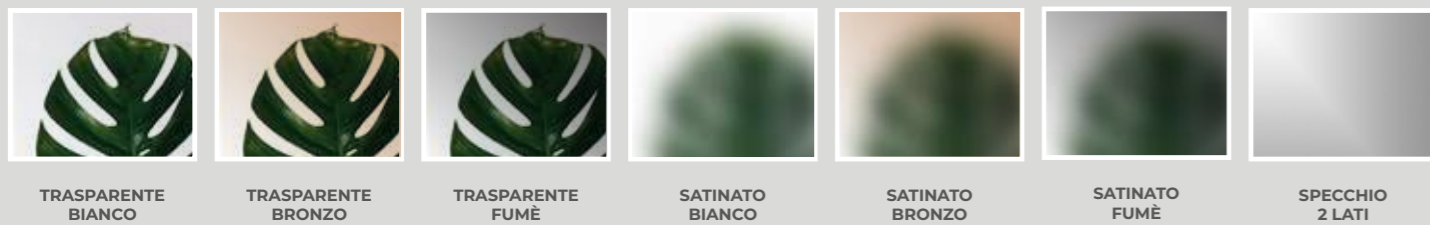

PARTICOLARE LEGGERA PANTOGRAFATE
LEGGERA PANTOGRAPHED DETAIL
DÉTAIL LEGGERA PANTOGRAPHES

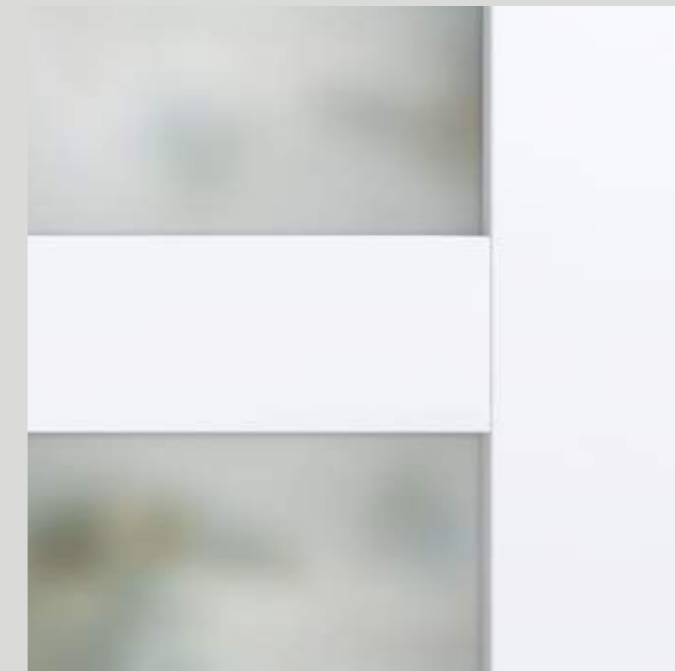

PARTICOLARE LEGGERA PANTOGRAFATE CON VETRO
LEGGERA PANTOGRAPHED WITH GLASS DETAIL
DÉTAIL LEGGERA PANTOGRAPHES VITRÉ

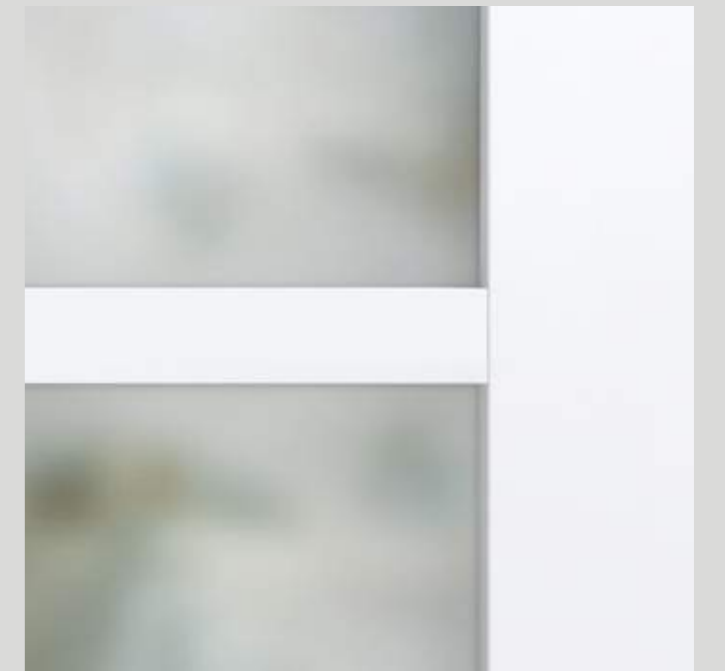

PARTICOLARE LEGGERA PANTOGRAFATE INGLESE
LEGGERA PANTOGRAPHED ENGLISH VERSION DETAIL
DÉTAIL LEGGERA PANTOGRAPHES VERSION ANGLAISE

LEGGERA
Pantografata Laccato

PANTOGRAPHED LEGGERA LACQUERED
LEGGERA PANTOGRAPHES LAQUÉ



TAKI - V



TAKI - P

LEGGERA Pantografata Laccato

PANTOGRAPHED LEGGERA LACQUERED
LEGGERA PANTOGRAPHES LAQUÉ



MARVEL - P



MARVEL - V

LEGGERA
Pantografata Laccato

PANTOGRAPHED LEGGERA LACQUERED
LEGGERA PANTOGRAPHES LAQUÉ



FELIX - I



FELIX - P

LEGGERA
Pantografata Laccato

PANTOGRAPHED LEGGERA LACQUERED
LEGGERA PANTOGRAPHES LAQUÉ



SHIVA - P



SHIVA - P

Texture
TEXTURE / TEXTURE
EXEA



ALU in EXEA® - Inserti in Alluminio

ALUMINIUM INSERTS
BAGUETTES EN ALUMINIUM

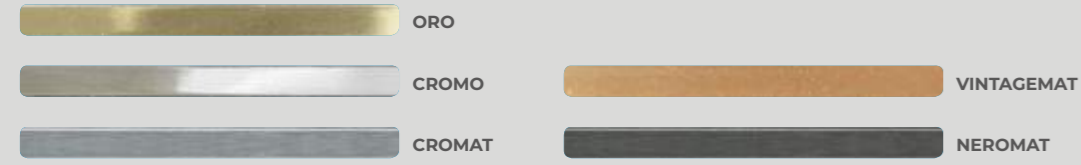

PARTICOLARE INSERTO ALLUMINIO
ALUMINIUM INSERT DETAIL
DÉTAIL INSERT EN ALUMINIUM

CRYSTAL in EXEA® - Versione Vetro

GLASS VERSION
VERSION POUR VITRE



V. MINIMAL
IN...



V. TOTAL
IN...



V. TRIAL
IN...



V. DUAL
IN...



TRASPARENTE
BIANCO



TRASPARENTE
BRONZO



TRASPARENTE
FUMÈ



SATINATO
BIANCO

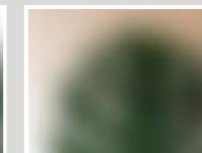

SATINATO
BRONZO

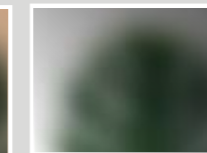

SATINATO
FUMÈ



SPECCHIO
2 LATI

Le versioni vetro sopra indicate non sono realizzabili sui modelli:
ANDROMEDA, BALI, COOK, DRACO, ELGON, GEMINA, HALMAHERA, IDRA, KEA, KIRAT, KOLA,
LEO, LOGAN, LYNX, MALAITA, MALTA, META, ORION, PEGASUS, PRADO, TETON, VIRGO.

The glass versions above are not available on the models:
ANDROMEDA, BALI, COOK, DRACO, ELGON, GEMINA, HALMAHERA, IDRA, KEA, KIRAT, KOLA,
LEO, LOGAN, LYNX, MALAITA, MALTA, META, ORION, PEGASUS, PRADO, TETON, VIRGO.

Les versions en verre ci-dessus ne sont pas disponibles sur les modèles:
ANDROMEDA, BALI, COOK, DRACO, ELGON, GEMINA, HALMAHERA, IDRA, KEA, KIRAT, KOLA,
LEO, LOGAN, LYNX, MALAITA, MALTA, META, ORION, PEGASUS, PRADO, TETON, VIRGO.

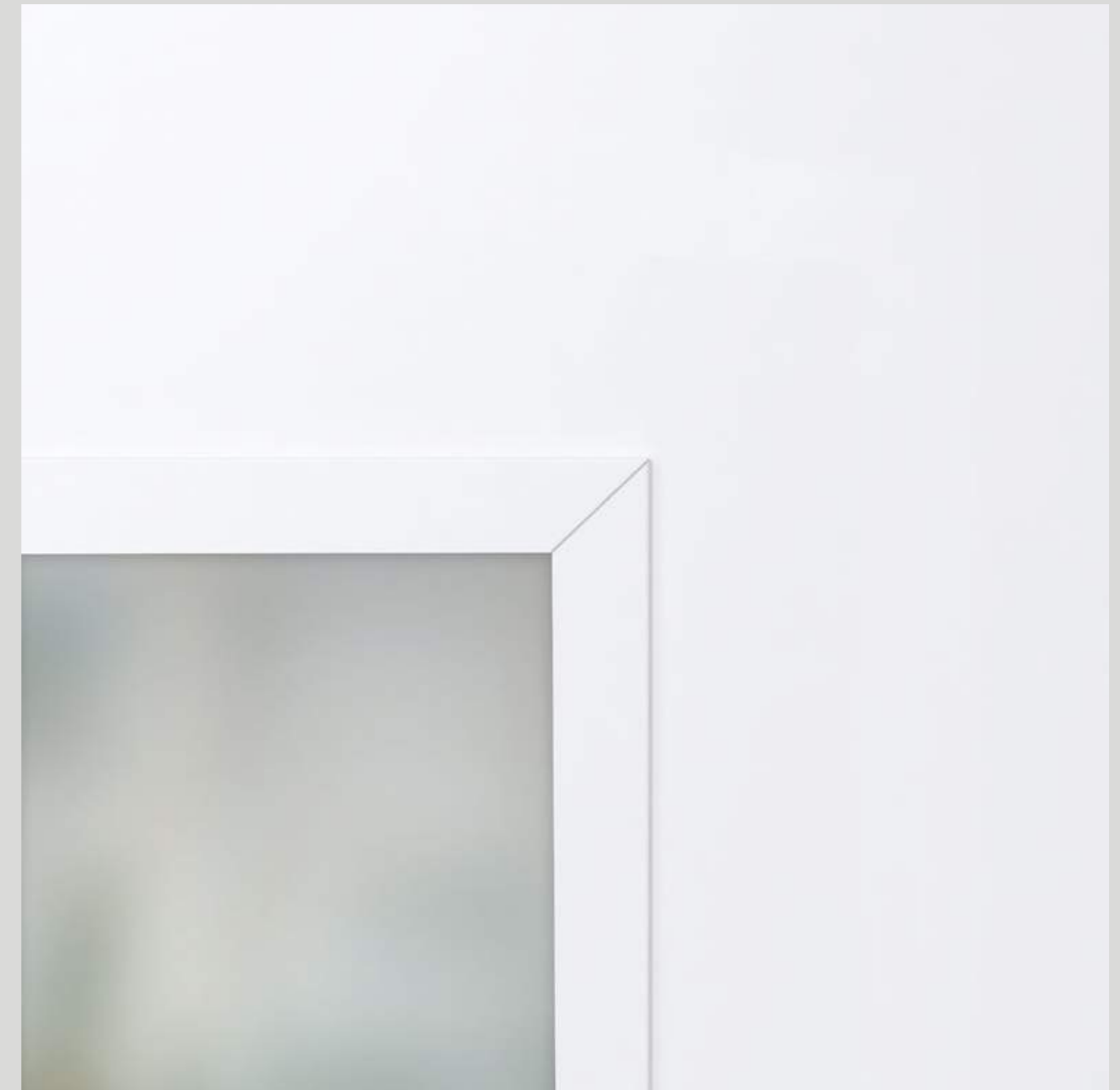

PARTICOLARE FERMAVETRO
GLASS HOLDER DETAIL
DÉTAIL PORTE-VITRÉ

SLAB in EXEA® - Vetri Strutturale

STRUCTURAL GLASS
VITRE STRUCTUREL



V. AVENUE
IN...



V. PLACE
IN...



V. ROAD
IN...



V. SLIM
IN...



V. FINGER
IN...



TRASPARENTE
BIANCO



TRASPARENTE
BRONZO



TRASPARENTE
FUMÈ



SATINATO
BIANCO

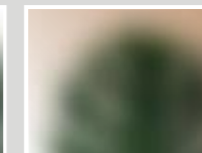

SATINATO
BRONZO

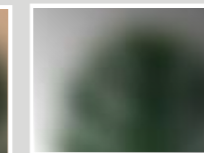

SATINATO
FUMÈ



SPECCHIO
2 LATI

Le versioni vetro sopra indicate non sono realizzabili sui modelli:
ANDROMEDA, BALI, COOK, DRACO, ELGON, GEMINA, HALMAHERA, IDRA, KEA, KIRAT, KOLA,
LEO, LOGAN, LYNX, MALAITA, MALTA, META, ORION, PEGASUS, PRADO, TETON, VIRGO.

The glass versions above are not available on the models:
ANDROMEDA, BALI, COOK, DRACO, ELGON, GEMINA, HALMAHERA, IDRA, KEA, KIRAT, KOLA,
LEO, LOGAN, LYNX, MALAITA, MALTA, META, ORION, PEGASUS, PRADO, TETON, VIRGO.

Les versions en verre ci-dessus ne sont pas disponibles sur les modèles:
ANDROMEDA, BALI, COOK, DRACO, ELGON, GEMINA, HALMAHERA, IDRA, KEA, KIRAT, KOLA,
LEO, LOGAN, LYNX, MALAITA, MALTA, META, ORION, PEGASUS, PRADO, TETON, VIRGO.

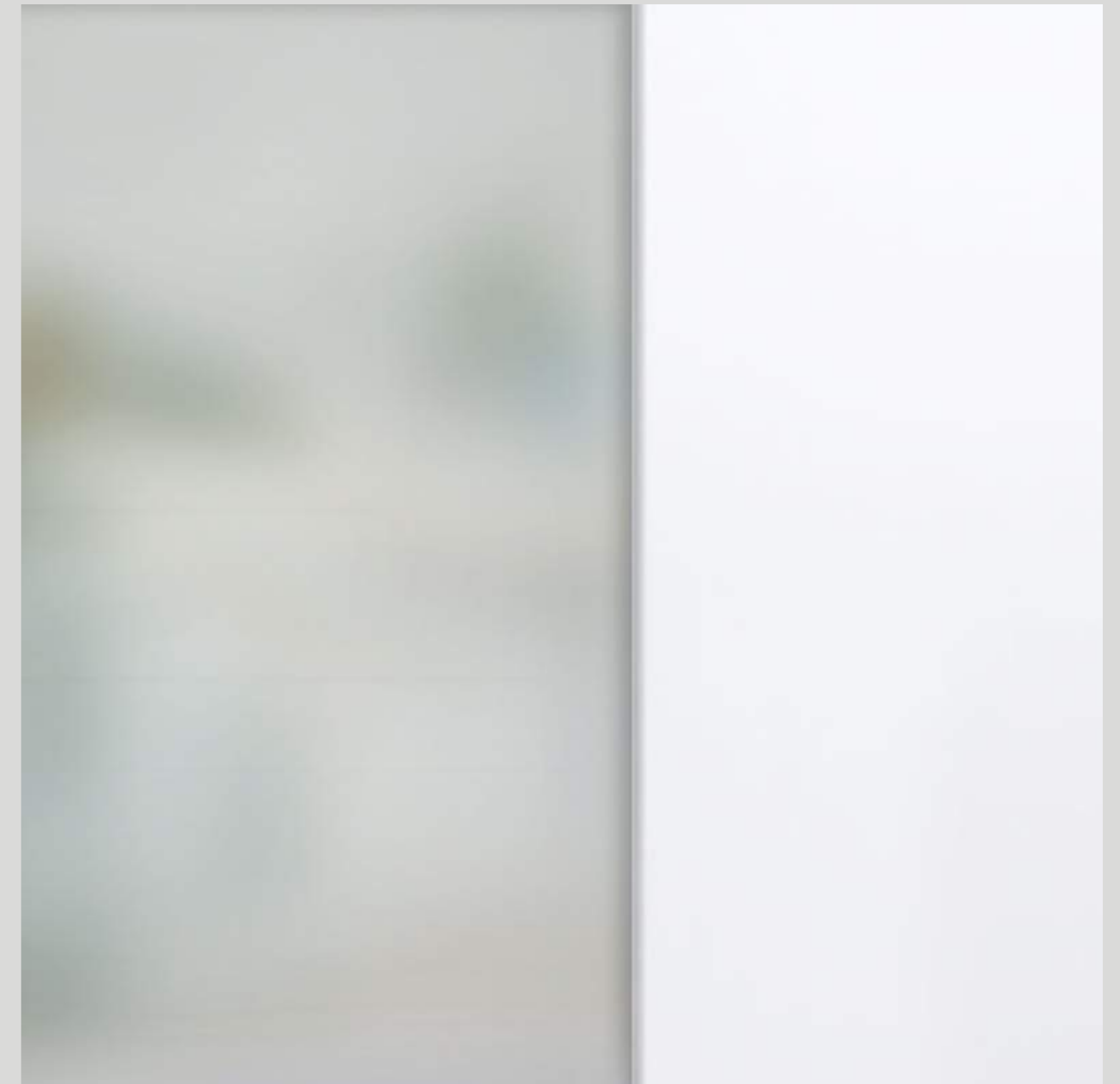

PARTICOLARE VETRO STRUTTURALE STRATIFICATO 4+4
STRUCTURAL STRATIFIED GLASS 4+4 DETAIL
DÉTAIL VITRE STRATIFIÉ 4+4 STRUCTUREL

STRIPE in EXEA® - Vetrolaccato

BACK PAINTED GLASS
VITRE RETROLAQUÈ



VLV IN ...



VGV IN ...



VTV IN ...



VGO IN ...



SOFT
WHITE



SOFT
BROWN



BLACK

Le versioni vetro sopra indicate non sono realizzabili sui modelli:
ANDROMEDA, BALI, COOK, DRACO, ELGON, GEMINA, HALMAHERA, IDRA, KEA, KIRAT, KOLA,
LEO, LOGAN, LYNX, MALAITA, MALTA, META, ORION, PEGASUS, PRADO, TETON, VIRGO.

The glass versions above are not available on the models:
ANDROMEDA, BALI, COOK, DRACO, ELGON, GEMINA, HALMAHERA, IDRA, KEA, KIRAT, KOLA,
LEO, LOGAN, LYNX, MALAITA, MALTA, META, ORION, PEGASUS, PRADO, TETON, VIRGO.

Les versions en verre ci-dessus ne sont pas disponibles sur les modèles:
ANDROMEDA, BALI, COOK, DRACO, ELGON, GEMINA, HALMAHERA, IDRA, KEA, KIRAT, KOLA,
LEO, LOGAN, LYNX, MALAITA, MALTA, META, ORION, PEGASUS, PRADO, TETON, VIRGO.



PARTICOLARE VETRO RETROLACCATO - LUCE NON PASSANTE
BACK-PAINTED LACQUERED GLASS DETAIL - NON TRANSPARENT
DÉTAIL DU VITRE RÉTROLAQUÉ - NON TRASPARENTE

EXEA
Bianco

TEXTURE BIANCO
TEXTURE BIANCO



BOAVISTA



AF CROMAT
IN BOAVISTA ¹

¹
Versione applicabile a tutti i modelli TEXTURE
The version can be applied to every TEXTURE models
Version disponible pour tous les TEXTURE modèles

²
Verificare fattibilità modello TEXTURE pag. 270
Check feasibility TEXTURE models pag. 270
Vérifier la faisabilité des modèles TEXTURE pag. 270



AL CROMO
IN BOAVISTA ¹

V.TOTAL IN
BOAVISTA ²

EXEA
Frassino Bianco

TEXTURE FRASSINO BIANCO
TEXTURE FRASSINO BIANCO

Anta Frassino Bianco
Telaio e Coprifilo Liscio Bianco

Frassino Bianco Panel
Smooth White Frame and Casing

Panneau Frassino Bianco
Cadre et Couvre-joints Lisses Blanc



GOMERA*

*
Porte Telaio e coprifilo laccato LISCIO
Doors with SMOOTH Lacquered Frame and Casing
Portes avec Cadre et Couvre-joints Laqué LISSEE



GRAZIOSA*

EXEA

Poroaperto Bianco

TEXTURE POROAPERTO BIANCO
TEXTURE POROAPERTO BIANCO

Anta Poroaperto Bianco
Telaio e Coprifilo Liscio Bianco

Poroaperto Bianco Panel
Smooth White Frame and Casing

Panneau Poroaperto Bianco
Cadre et Couvre-joints Lisses Blanc



RAIAMEA*

*
Porte Telaio e coprifilo laccato LISCIO
Doors with SMOOTH Lacquered Frame and Casing
Portes avec Cadre et Couvre-joints Laqué LISSEE



RIKITEA*

EXEA
Spazzolato Bianco

TEXTURE SPAZZOLATO BIANCO
TEXTURE SPAZZOLATO BIANCO

Anta Spazzolato Bianco
Telaio e Coprifilo Liscio Bianco

Spazzolato Bianco Panel
Smooth Bianco Frame and Casing

Panneau Spazzolato Bianco
Cadre et Couvre-joints Lisse Bianco



A B E D O R *

*
Porte Telaio e coprifilo laccato LISCIO
Doors with SMOOTH Lacquered Frame and Casing
Portes avec Cadre et Couvre-joints Laqué LISSEE



I A S A *

EXEA
Spazzolato Bianco

TEXTURE SPAZZOLATO BIANCO
TEXTURE SPAZZOLATO BIANCO

Anta Spazzolato Bianco
Telaio e Coprifilo Spazzolato Bianco

Spazzolato Bianco Panel
White Spazzolato Frame and Casing

Panneau Spazzolato Bianco
Cadre et Couvre-joints Spazzolato Blanc

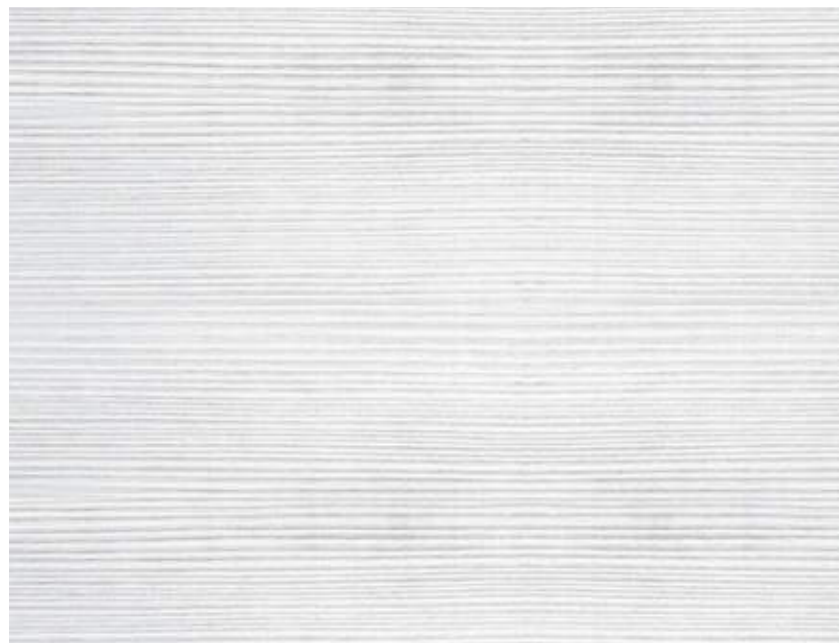

EXEA

Spazzolato Bianco

FINISHING SPAZZOLATO BIANCO
FINITION SPAZZOLATO BIANCO



A Z C R O M O
I N M A D E I R A ¹



V T V
I N M A D E I R A ²



V . M I N I M A L
I N A R U B A ²

¹
Versione applicabile a tutti i modelli TEXTURE
The version can be applied to every TEXTURE models
Version disponible pour tous les TEXTURE modèles

²
Verificare fattibilità modello TEXTURE pag. 274
Check feasibility TEXTURE models pag. 274
Vérifier la faisabilité des modèles TEXTURE pag. 274

²
Verificare fattibilità modello TEXTURE pag. 270
Check feasibility TEXTURE models pag. 270
Vérifier la faisabilité des modèles TEXTURE pag. 270



EXEA
Aavorio

TEXTURE AVORIO
TEXTURE AVORIO



AP CROMO
IN MAURITIUS¹



MAURITIUS



AT CROMO
IN MAURITIUS¹



¹
Versione applicabile a tutti i modelli TEXTURE
The version can be applied to every TEXTURE models
Version disponible pour tous les TEXTURE modèles

EXEA
Spazzolato Avorio

TEXTURE SPAZZOLATO AVORIO
TEXTURE SPAZZOLATO AVORIO

Anta Spazzolato Avorio
Telaio e Coprifilo Liscio Avorio

Spazzolato Avorio Panel
Smooth Ivory Frame and Casing

Panneau Spazzolato Avorio
Cadre et Couvre-joints Lisses Ivoire



MURUROA



MATAURA

EXEA
Matrix

TEXTURE MATRIX
TEXTURE MATRIX



AK VINTAGEMAT
IN CRETA¹



CRETA

¹
Versione applicabile a tutti i modelli TEXTURE
The version can be applied to every TEXTURE models
Version disponible pour tous les TEXTURE modèles

²
Verificare fattibilità modello TEXTURE pag. 274
Check feasibility TEXTURE models pag. 274
Vérifier la faisabilité des modèles TEXTURE pag. 274



VLV
IN CRETA²

EXEA
Concrete

TEXTURE CONCRETE
TEXTURE CONCRETE

Anta Concrete
Telaio e Coprifilo Liscio Laccato

Concrete Panel
Smooth Lacquered Frame and Casing

Panneau Concrete
Cadre et Couvre-joints Laqué Lisse



CONCRETE
LEVEL

*
Telaio e coprifilo laccato TONALIZZATO
Frame and Casing Lacquered TONALIZED
Cadre et Couvre-joints Laqué TONALISÉ

**
Telaio e coprifilo laccato A RICHIESTA
Frame and Casing Lacquered ON REQUEST
Cadre et Couvre-joints Laqué SUR DEMANDE



ZAIRGA*

CELIA**

EXEA
Cement

TEXTURE CEMENT
TEXTURE CEMENT

Anta Cement
Telaio e Coprifilo Liscio Laccato

Cement Panel
Smooth Lacquered Frame and Casing

Panneau Cement
Cadre et Couvre-joints Laqué Lisse



VLV
IN CEMENT 2

Verificare fattibilità modello TEXTURE pag. 274
Check feasibility TEXTURE models pag. 274
Vérifier la faisabilité des modèles TEXTURE pag. 274



ISLEA *

AURAL **

*
Telaio e coprifilo laccato TONALIZZATO
Frame and Casing Lacquered TONALIZED
Cadre et Couvre-joints Laqué TONALISÉ

**
Telaio e coprifilo laccato A RICHIESTA
Frame and Casing Lacquered ON REQUEST
Cadre et Couvre-joints Laqué SUR DEMANDE

EXEA
Rovere Artico

TEXTURE ROVERE ARTICO
TEXTURE ROVERE ARTICO



CLEO



CIPRIA

EXEA
Rovere Artico

TEXTURE ROVERE ARTICO
TEXTURE ROVERE ARTICO



VLV
IN CLEO²

2
Verificare fattibilità modello TEXTURE pag. 274
Check feasibility TEXTURE models pag. 274
Vérifier la faisabilité des modèles TEXTURE pag. 274

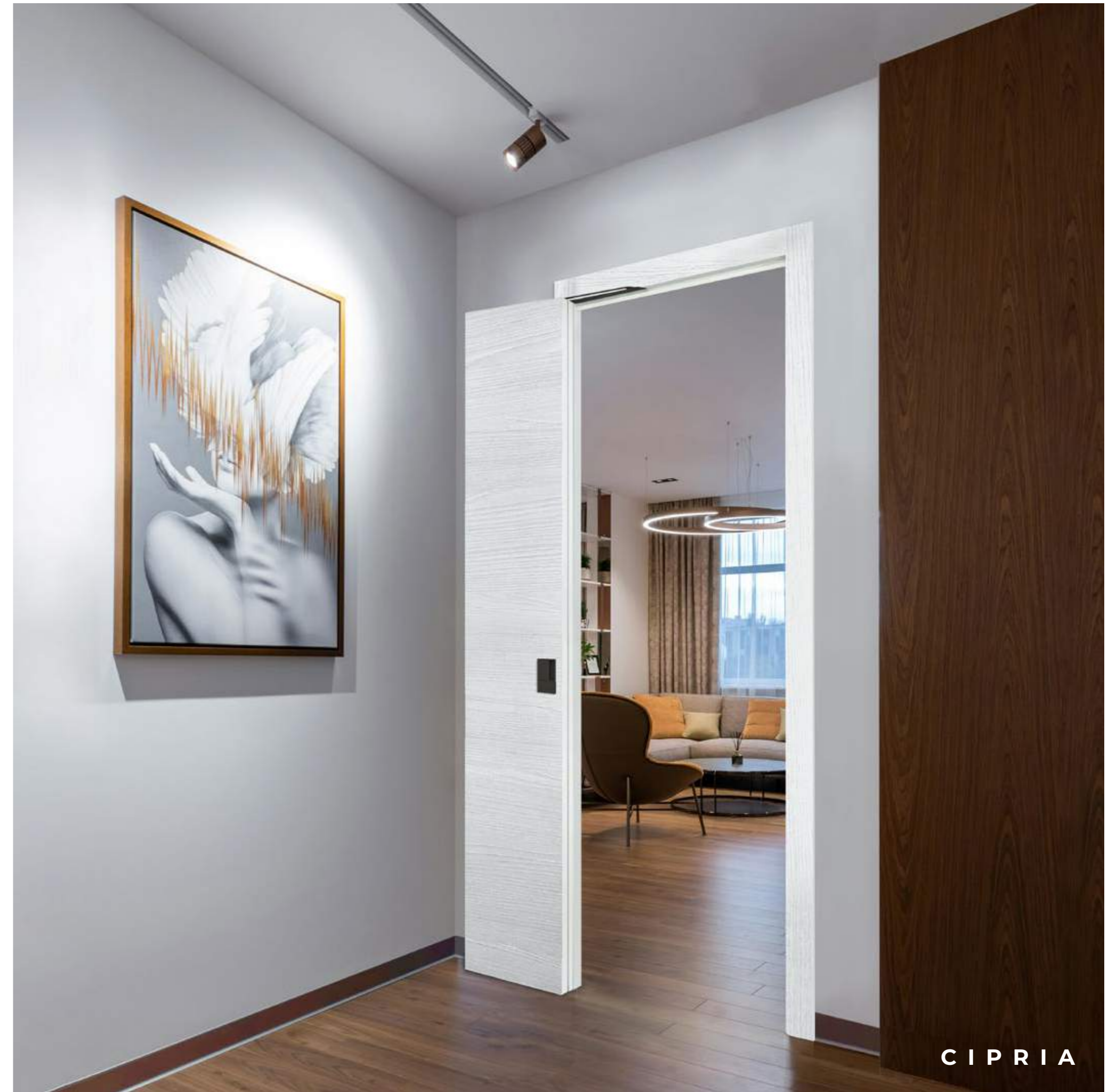

EXEA
Rovere Country

TEXTURE ROVERE COUNTRY
TEXTURE ROVERE COUNTRY



C O R T E G A D A



P A N C A I A

EXEA
Rovere Country

TEXTURE ROVERE COUNTRY
TEXTURE ROVERE COUNTRY



AG NEROMAT
IN CORTEGADA¹

¹ Versione applicabile a tutti i modelli TEXTURE
The version can be applied to every TEXTURE models
Version disponible pour tous les TEXTURE modèles



PANCAIA

EXEA
Rovere Ambient

TEXTURE ROVERE AMBIENT
TEXTURE ROVERE AMBIENT



HONDURAS



NICARAGUA

EXEA

Rovere Ambient

TEXTURE ROVERE AMBIENT
TEXTURE ROVERE AMBIENT



COOK



ELGON



PRADO

EXEA

Rovere Cenere

TEXTURE ROVERE CENERE
TEXTURE ROVERE CENERE



ACQUARIUS



CRUX

EXEA

Rovere Cenere

TEXTURE ROVERE CENERE
TEXTURE ROVERE CENERE



GEMINA



PEGASUS



LYNX

EXEA
Rovere Fiamma

TEXTURE ROVERE FIAMMA
TEXTURE ROVERE FIAMMA



VIRGO



DORADO

EXEA

Rovere Fiamma

TEXTURE ROVERE FIAMMA
TEXTURE ROVERE FIAMMA



ANDROMEDA



IDRA



CETUS

EXEA
Rovere Fuoco

TEXTURE ROVERE FUOCO
TEXTURE ROVERE FUOCO



SAGITTA



CASSIOPEA

EXEA
Rovere Fuoco

TEXTURE ROVERE FUOCO
TEXTURE ROVERE FUOCO



DRACO



LEO

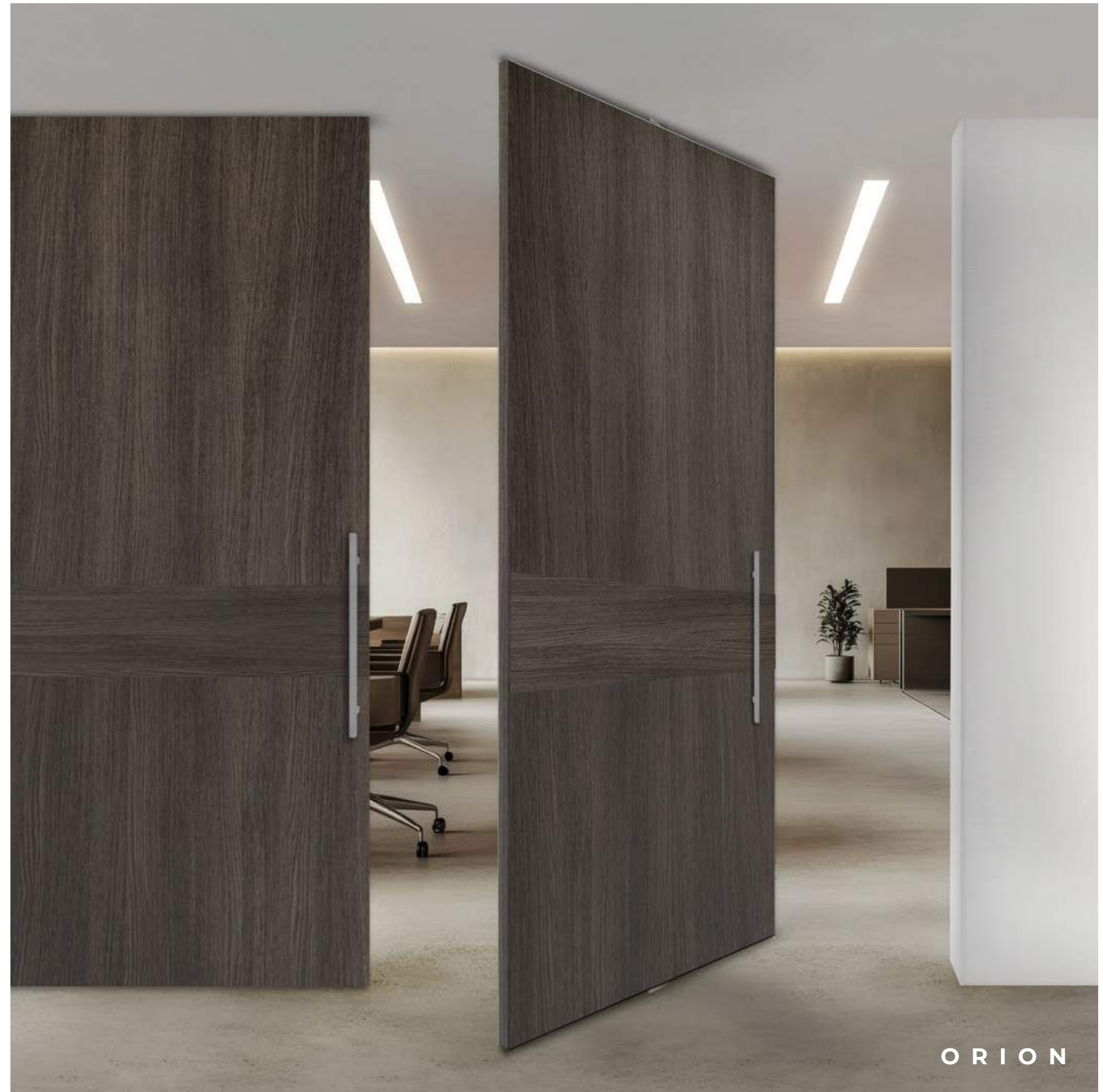

ORION

EXEA

Rovere Sahara

TEXTURE ROVERE SAHARA
TEXTURE ROVERE SAHARA



V. PLACE
IN CEYLON²



SAMAR



V. ROAD
IN SAMAR²

²
Verificare fattibilità modello TEXTURE pag. 272
Check feasibility TEXTURE models pag. 272
Vérifier la faisabilité des modèles TEXTURE pag. 272

EXEA
Biovintage

TEXTURE BIOVINTAGE
TEXTURE BIOVINTAGE



LABRADOR



YUCATAN

EXEA
Biovintage

TEXTURE BIOVINTAGE
TEXTURE BIOVINTAGE



K O L A



M E T A



K E A

EXEA
Walnut Usa

TEXTURE WALNUT USA
TEXTURE WALNUT USA



VTV IN
DOMINICA²



DOMINICA



CURACAO

²
Verificare fattibilità modello TEXTURE pag. 274
Check feasibility TEXTURE models pag. 274
Vérifier la faisabilité des modèles TEXTURE pag. 274

EXEA
Walnut Usa

TEXTURE WALNUT USA
TEXTURE WALNUT USA



KIRAT



LOGAN



TETON

EXEA
Noce Clear

TEXTURE NOCE CLEAR
TEXTURE NOCE CLEAR



MALAITA



BARBADOS



LA PALMA

EXEA
Noce Nazionale

TEXTURE NOCE NAZIONALE
TEXTURE NOCE NAZIONALE



G I A V A

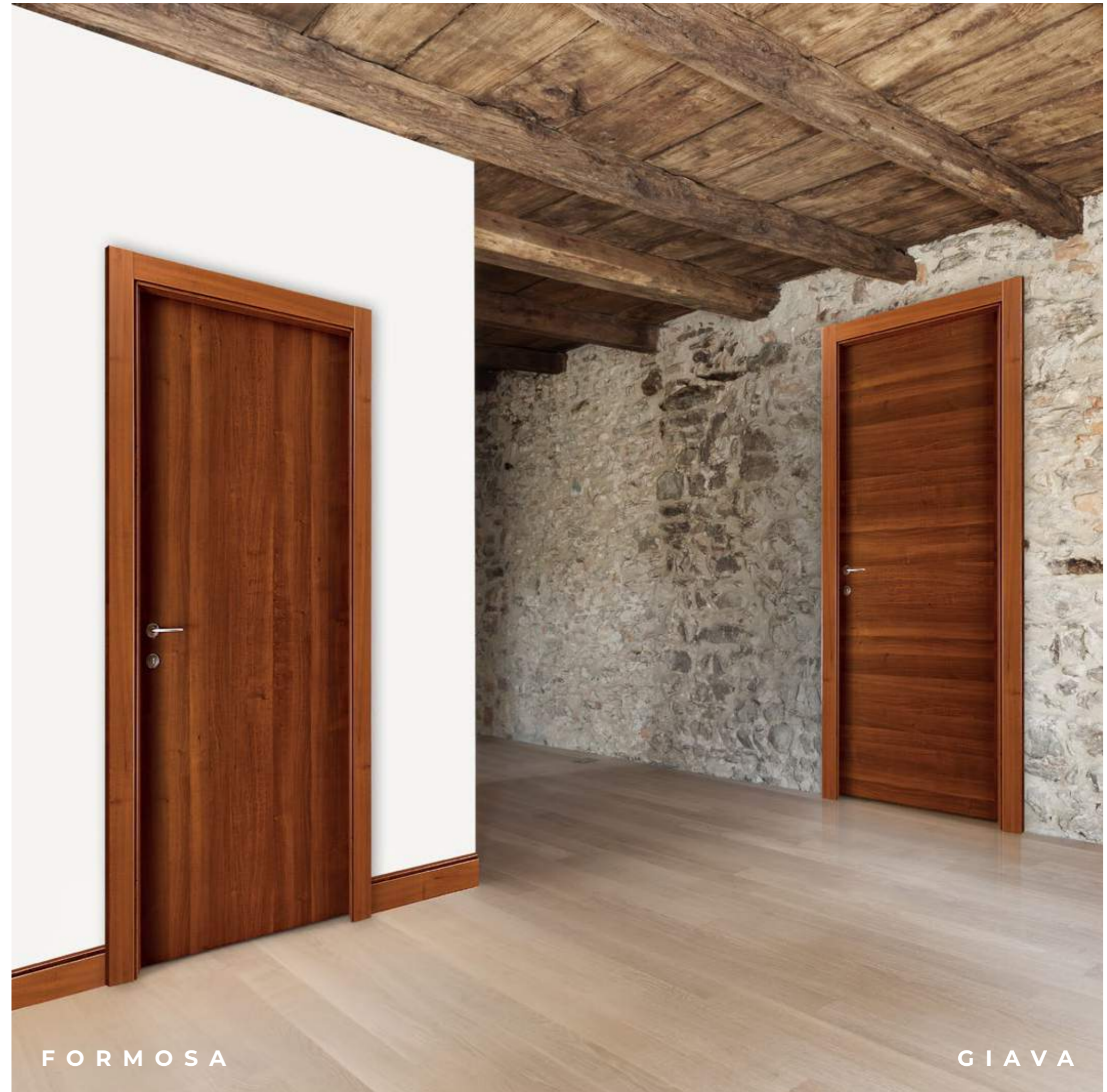

F O R M O S A

G I A V A

EXEA
Ciliegio

TEXTURE CILIEGIO
TEXTURE CILIEGIO



AY CROMAT
IN VITTORIA¹



VITTORIA



MARAJO

¹
Versione applicabile a tutti i modelli TEXTURE
The version can be applied to every TEXTURE models
Version disponible pour tous les TEXTURE modèles

Legni
WOOD / BOIS
WOODY

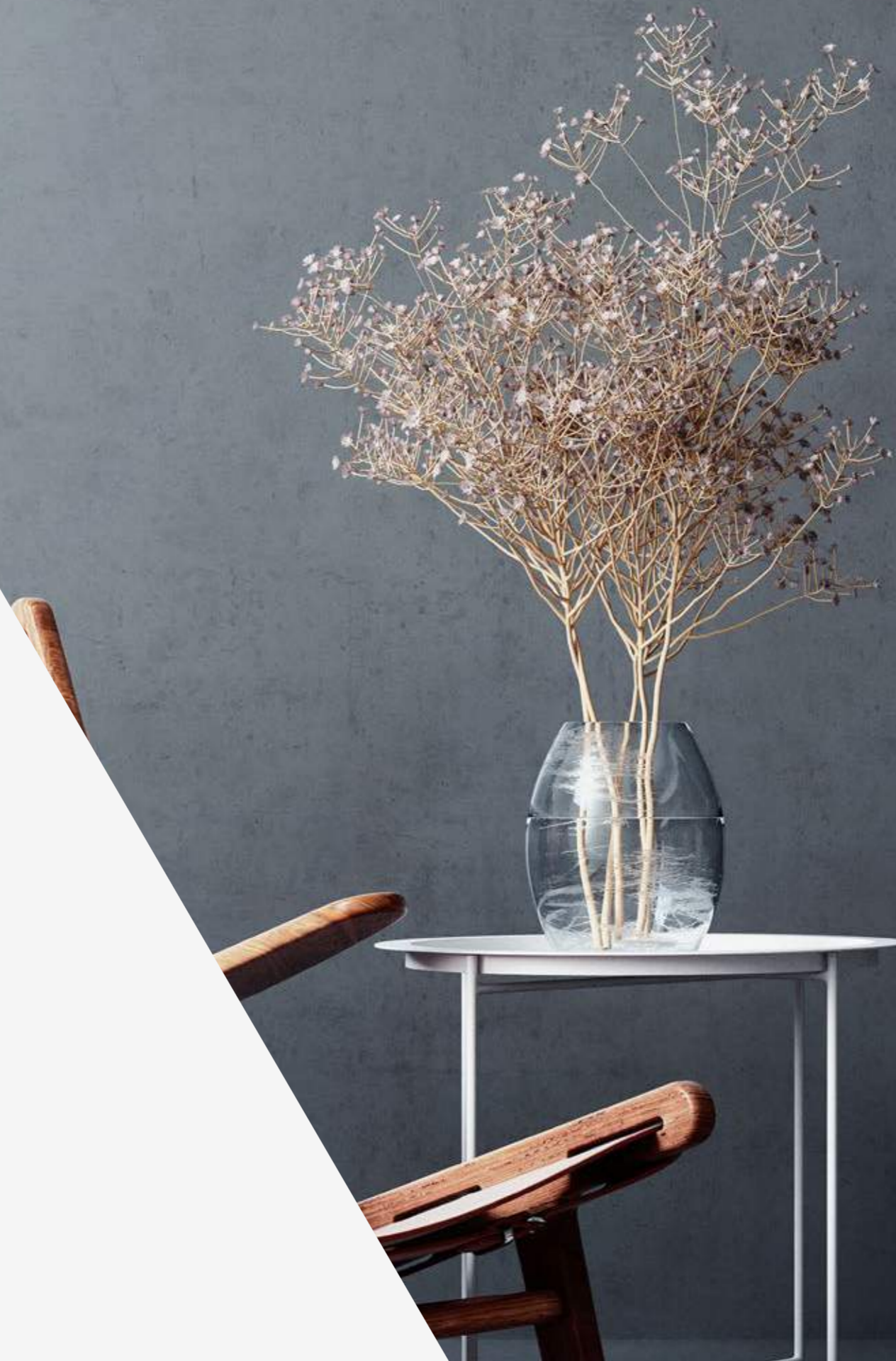

ALU in WOODY - Inserti in Alluminio

ALUMINIUM INSERTS
INSERTS EN ALUMINIUM



PARTICOLARE INSERTO IN ALLUMINIO
ALUMINUM INSERT DETAIL
DÉTAIL INSERT EN ALUMINIUM

SLAB in WOODY - Vetro Strutturale

STRUCTURAL GLASS
VITRESTRUCTUREL



V. AVENUE
IN...



V. PLACE
IN...



V. ROAD
IN...



V. SLIM
IN...



V. FINGER
IN...



TRASPARENTE
BIANCO



TRASPARENTE
BRONZO



TRASPARENTE
FUMÈ



SATINATO
BIANCO

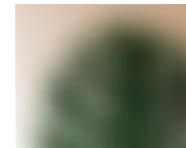

SATINATO
BRONZO

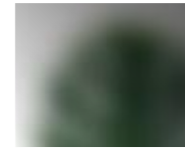

SATINATO
FUMÈ



SPECCHIO
2 LATI



... CALABASAS



... CATALINA



... NEWPORT



... NAPA



... FORTUNA



... FAIRFAX



... TAMPA



... TONALEA



... RIALTO



... RAGLAND



PARTICOLARE VETRO STRUTTURALE STRATIFICATO 4+4
STRUCTURAL STRATIFIED GLASS 4+4 DETAIL
DÉTAIL VITRE STRATIFIÉ 4+4 STRUCTUREL

STRIPE in WOODY - Vetro Retrolaccato

STRIPE BACK PAINTED GLASS
STRIPE VITRE RETROLAQUÉ



VLV IN ...



VGV IN ...



VTV IN ...



VGO IN ...



SOFT
WHITE



SOFT
BROWN



BLACK



...CALABASAS



...CATALINA



...NEWPORT



...NAPA



...FORTUNA



...FAIRFAX



...TAMPA



...TONALEA



...RIALTO



...RAGLAND



PARTICOLARE VETRO RETROLACCATO - LUCE NON PASSANTE
BACK-PAINTED GLASS DETAIL - NON TRANSPARENT
DÉTAIL DU VITRE RÉTROLAQUÉ - NON TRASPARENTE

WOODY - Canaletto

CANALETTO
CANALETTO



CALABASAS **CATALINA** **CORONA** **CALIMESA** **COVINA** **CASSINDRA** **CLYMORA** **CALENDOR**
CANALETTO NATURALE TOUCH CANALETTO NATURALE TOUCH CANALETTO NATURALE TOUCH CANALETTO NATURALE TOUCH CANALETTO NATURALE TOUCH CANALETTO NATURALE TOUCH CANALETTO NATURALE TOUCH CANALETTO NATURALE TOUCH



CANALETTO NATURALE TOUCH **CANALETTO LIGHT TOUCH** **CANALETTO COOL TOUCH** **CANALETTO ARDESIA TOUCH**



CANALETTO NATURALE TOUCH

WOODY
Canaletto

WOOD CANALETTO
BOIS CANALETTO



CORONA
CANALETTO COOL TOUCH



CATALINA
CANALETTO COOL TOUCH



COVINA
CANALETTO LIGHT TOUCH

WOODY Canaletto

WOOD CANALETTO
BOIS CANALETTO



VGV
IN CALABASAS¹
CANALETTO NATURALE TOUCH

¹ Versione applicabile a tutti i modelli sezione LEGNI
The version can be applied to every WOOD models
Version disponible pour tous les BOIS modèles



VLV
IN CATALINA¹
CANALETTO ARDESIA TOUCH

WOODY Canaletto

WOOD CANALETTO
BOIS CANALETTO



WOODY - Noce Nazionale

NATIONAL WALNUT
NOIX NATIONALE



NEWPORT

NOCE
NAZIONALE
NATURALE
TOUCH



NAPA

NOCE
NAZIONALE
NATURALE
TOUCH



NEVADA

NOCE
NAZIONALE
NATURALE
TOUCH



NIXON

NOCE
NAZIONALE
NATURALE
TOUCH



NELSON

NOCE
NAZIONALE
NATURALE
TOUCH



NORVELLA

NOCE
NAZIONALE
NATURALE
TOUCH



NHARLOCK

NOCE
NAZIONALE
NATURALE
TOUCH



NARCADIA

NOCE
NAZIONALE
NATURALE
TOUCH

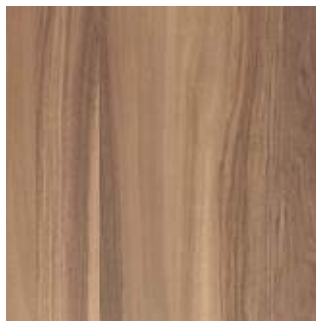

NOCE NAZIONALE
NATURALE TOUCH

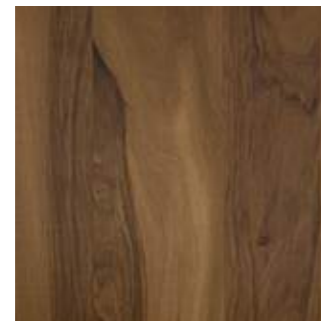

NOCE NAZIONALE
LIGHT TOUCH



NOCE NAZIONALE
CARBON TOUCH

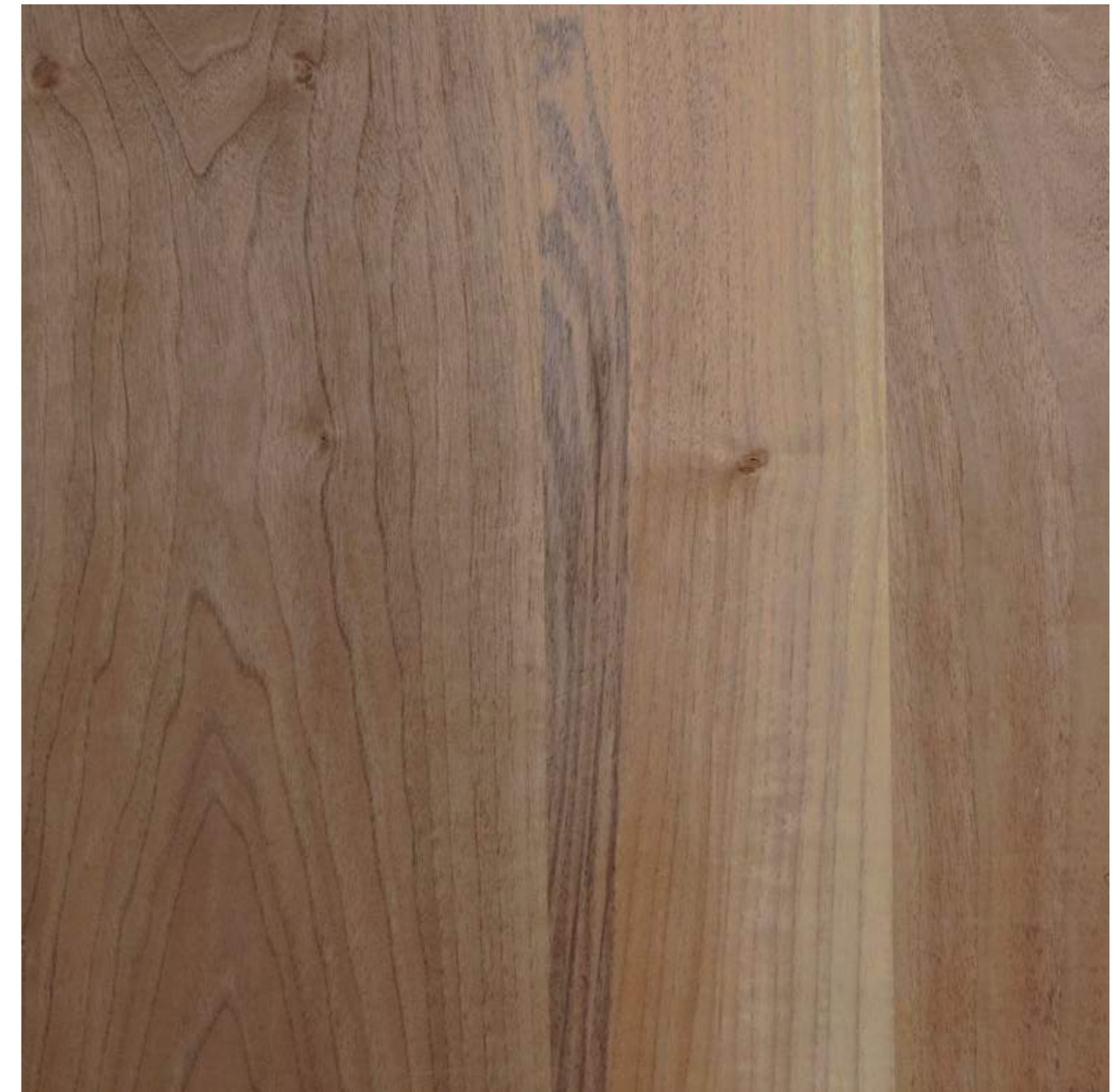

NOCE NAZIONALE NATURALE TOUCH

WOODY

Noce Nazionale

WOOD NATIONAL WALNUT
BOIS NOIX NATIONALE



NEVADA
NOCE NAZIONALE NATURALE TOUCH



NIXON
NOCE NAZIONALE NATURALE TOUCH



NAPA
NOCE NAZIONALE LIGHT TOUCH

WOODY Noce Nazionale

WOOD NATIONAL WALNUT
BOIS NOIX NATIONALE



VGO IN NAPAI
NOCE NAZIONALE LIGHT TOUCH



NELSON
NOCE NAZIONALE LIGHT TOUCH



VTV
IN NEWPORT I
NOCE NAZIONALE NATURALE TOUCH

¹ Versione applicabile a tutti i modelli sezione LEGNI
The version can be applied to every WOOD models
Version disponible pour tous les BOIS modèles

WOODY
Noce Nazionale

WOOD NATIONAL WALNUT
BOIS NOIX NATIONALE



NORVELLA
NOCE NAZIONALE NATURALE TOUCH



NHARLOCK
NOCE NAZIONALE LIGHT TOUCH



NARCADIA
NOCE NAZIONALE NATURALE TOUCH

WOODY - Frassino

ASH
FRÊNE

Andrea Castignano



FORTUNA

FRASSINO
GLAM TOUCH



FAIRFAX

FRASSINO
GLAM TOUCH



FRISCO

FRASSINO
GLAM TOUCH



FRANKLIN

FRASSINO
GLAM TOUCH



FLANGSTAFF

FRASSINO
GLAM TOUCH

EFFEZZERO DESIGN



FRASSINO
GLAM TOUCH



FRASSINO
COOL TOUCH

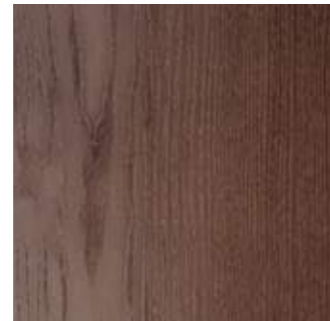

FRASSINO
THERMO TOUCH



FRASSINO
PORO LACCATO



*RAL
A RICHIESTA



FRASSINO GLAM TOUCH

EFFEZZERO DESIGN

WOODY
Frassino

WOOD ASH
BOIS FRÊNE



FRISCO
FRASSINO THERMO TOUCH



FAIRFAX
FRASSINO THERMO TOUCH



FRANKLIN
FRASSINO COOL TOUCH

EFEZZERO DESIGN

WOODY Frassino

WOOD ASH
BOIS FRÊNE



VGO
IN FORTUNA¹
FRASSINO GLAM TOUCH



VTV
IN FORTUNA¹
FRASSINO GLAM TOUCH

¹
Versione applicabile a tutti i modelli sezione LEGNI
The version can be applied to every WOOD models
Version disponible pour tous les BOIS modèles



VLV*¹
IN FORTUNA
FRASSINO PORO LACCATO

*
Porte Telaio e coprifilo laccato LISCIO
Doors with SMOOTH Lacquered Frame and Casing
Portes avec Cadre et Couvre-joints Laqué LISSEE

EFEZZERO DESIGN
WOODY
Frassino

WOOD ASH
BOIS FRÊNE



WOODY - Tanganika

TANGANIKA
TANGANIKA



TAMPA

TANGANIKA
VANIGLIA TOUCH



TONALEA

TANGANIKA
VANIGLIA TOUCH



TARRANT

TANGANIKA
VANIGLIA TOUCH



TIBURON

TANGANIKA
VANIGLIA TOUCH



TRAFFORD

TANGANIKA
VANIGLIA TOUCH



TANGANIKA
VANIGLIA TOUCH



TANGANIKA
GLAM TOUCH



TANGANIKA
COOL TOUCH



TANGANIKA
THERMO TOUCH

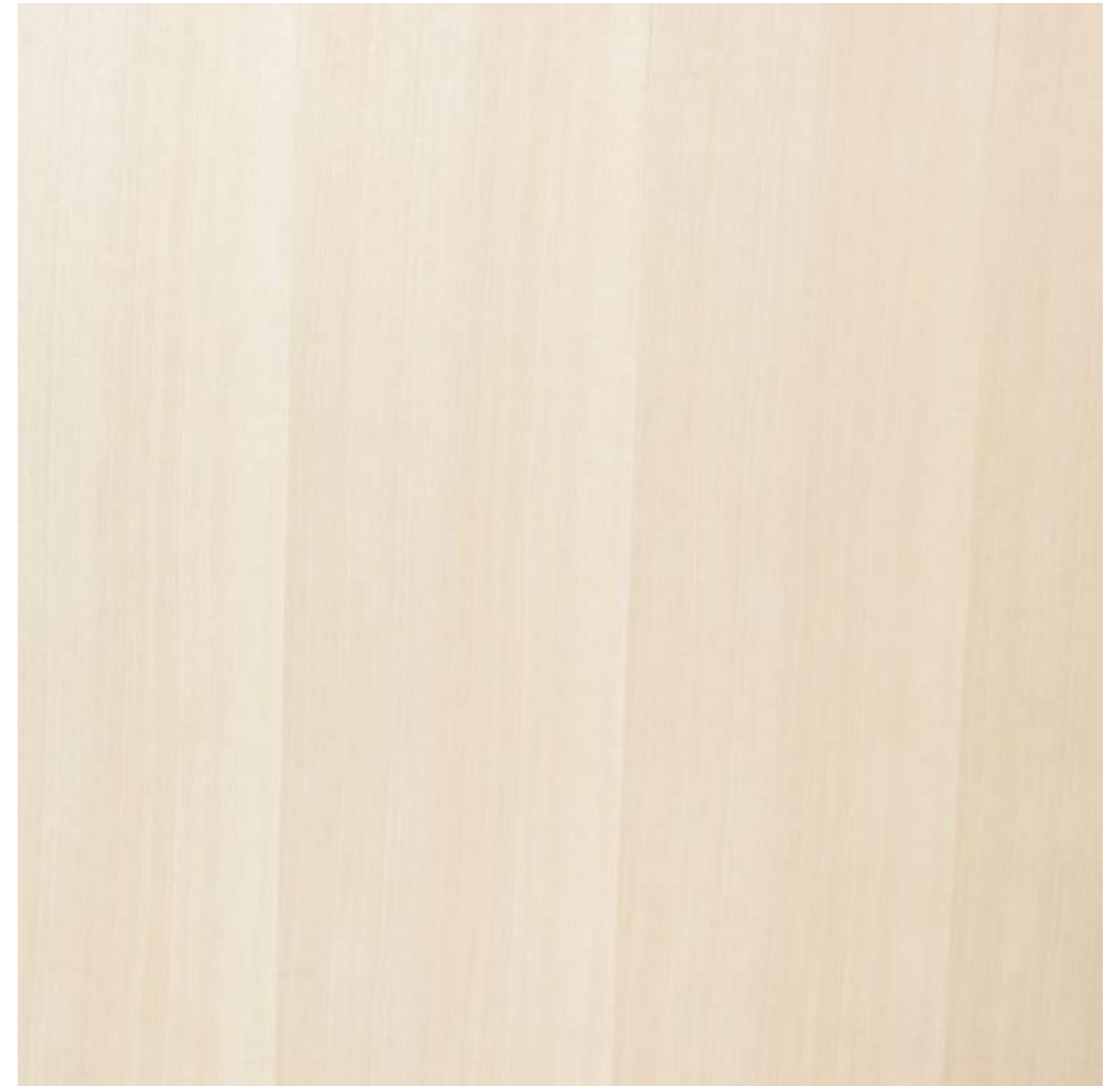

TANGANIKA VANIGLIA TOUCH

WOODY Tanganika

WOOD TANGANIKA
BOIS TANGANIKA



TIBURON
TANGANIKA VANIGLIA TOUCH



**AT CROMO
IN TONALEA¹**
TANGANIKA VANIGLIA TOUCH



**V. FINGER
IN TAMPA¹**
TANGANIKA VANIGLIA TOUCH

¹ Versione applicabile a tutti i modelli sezione LEGNI
The version can be applied to every WOOD models
Version disponible pour tous les BOIS modèles

WOODY Tanganika

WOOD TANGANIKA
BOIS TANGANIKA



TARRANT
TANGANIKA COOL TOUCH



TRAFFORD
TANGANIKA COOL TOUCH

¹
Versione applicabile a tutti i modelli sezione LEGNI
The version can be applied to every WOOD models
Version disponible pour tous les BOIS modèles



V. PLACE IN TAMPA¹
TANGANIKA GLAM TOUCH

WOODY - Rovere

OAK
CHÊNE



RIALTO

ROVERE
NATURALE
TOUCH



RAGLAND

ROVERE
NATURALE
TOUCH



REPTON

ROVERE
NATURALE
TOUCH



RATAMOSA

ROVERE
NATURALE
TOUCH



RIDVILLE

ROVERE
NATURALE
TOUCH



RHONIRA

ROVERE
NATURALE
TOUCH



RAVENDOR

ROVERE
NATURALE
TOUCH



RIVANTOS

ROVERE
NATURALE
TOUCH



ROVERE
VANIGLIA
TOUCH



ROVERE
NATURALE
TOUCH



ROVERE
LIGHT
TOUCH



ROVERE
THERMO
TOUCH

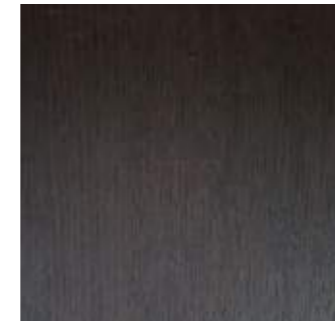

ROVERE
CARBON
TOUCH



ROVERE NATURALE TOUCH

WOODY
Rovere

WOOD OAK
BOIS CHÊNE



RATAMOSA
ROVERE LIGHT TOUCH



RIDGVILLE
ROVERE LIGHT TOUCH



RAGLAND
ROVERE THERMO TOUCH

WOODY
Rovere

WOOD OAK
BOIS CHÊNE



Glass
VETRI / GLASSES / VITRES
ART GLASS

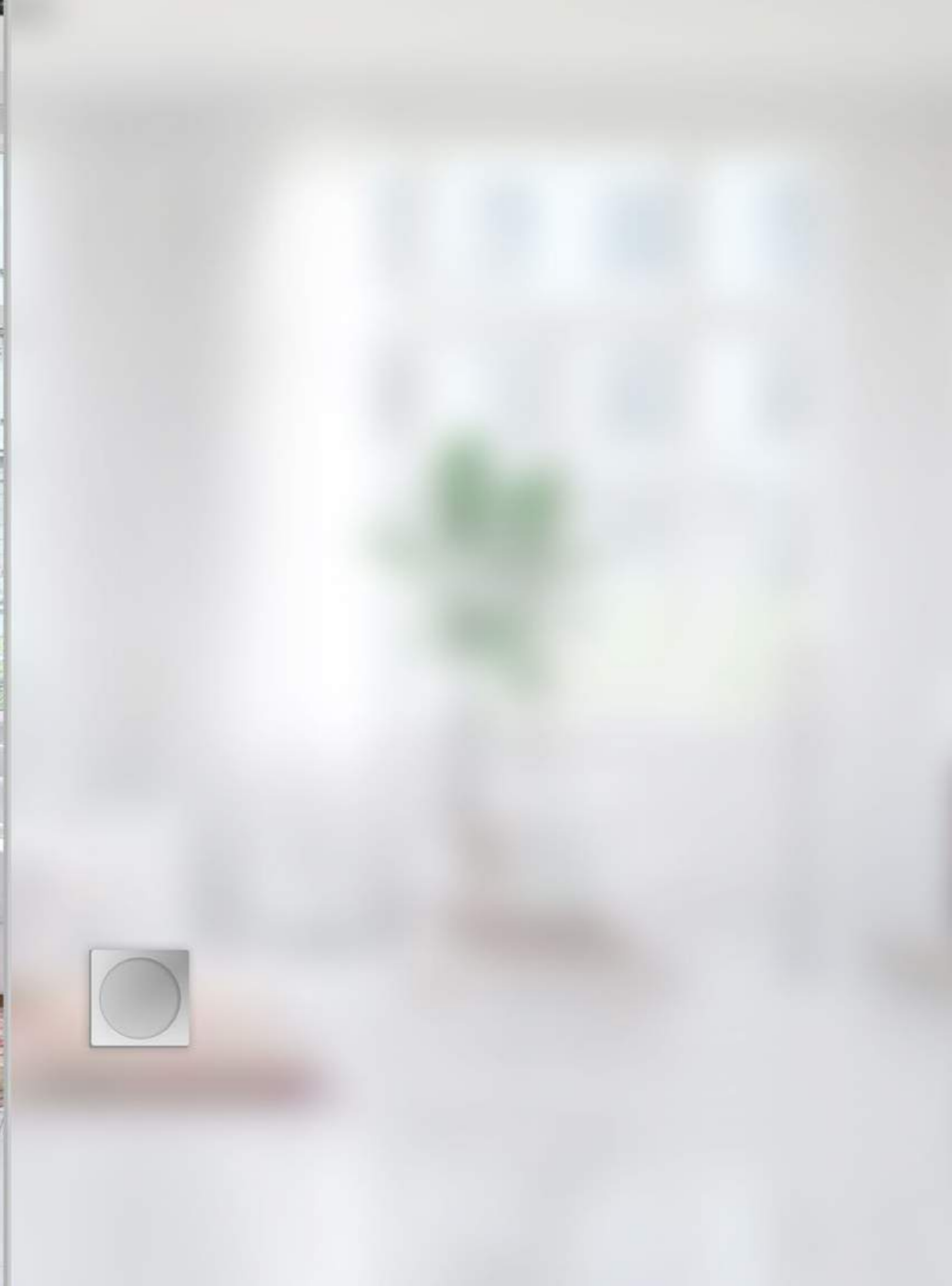

ART GLASS - Vetri

ART GLASS GLASSES
VITRES ART GLASS



EVA

Vetro Trasparente
Transparent Glass
Vitre Transparent



KIA

Vetro Satinato
Satinated Glass
Vitre Satiné



EVA BRONZO

Vetro Trasparente
Transparent Glass
Vitre Transparent



KIA BRONZO

Vetro Satinato
Satinated Glass
Vitre Satiné



EVA FUMÈ

Vetro Trasparente
Transparent Glass
Vitre Transparent



KIA FUMÈ

Vetro Satinato
Satinated Glass
Vitre Satiné

Colori per Linee e Disegni ART GLASS

COLOURS FOR ART GLASS LINES AND DRAWINGS
COULEURS POUR LIGNES ET DESSINS ART GLASS

Riferimento indicativo colori RAL
Indicative reference RAL Colours
Référence indicative couleurs RAL

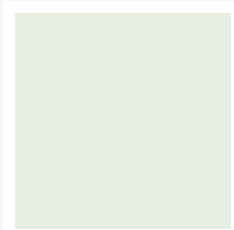

BIANCO



BEIGE GRIGIO



GRIGIO BEIGE

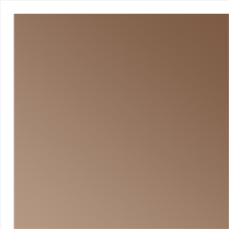

MARRONE



SEPPIA



SETA



TORTORA



ARGENTO



ARDESIA



NERO



ROSSO

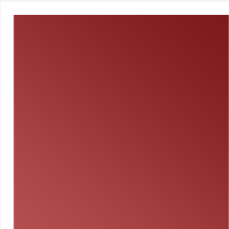

CARMINIO



ARANCIONE



INDACO

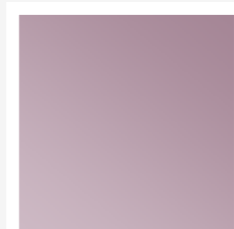

VIOLETTO



ART GLASS - Decori

ART GLASS DECORATIONS
DÉCORATIONS ART GLASS



ART GLASS - Ferramenta per Porte

ART GLASS DOOR HARDWARE
FERRAGE POUR PORTES ART GLASS

Serrature Lock / Serrure



GREENLAND
CROMO / CROMAT

Serratura Greenland senza maniglia
Greenland lock without handle
Serrure Greenland sans poignée

Maniglia per Scorrevole Flush Door-handle / Poignée de Porte Coulissante



SQUARE G
CROMO / CROMAT



ROUND G
CROMO / CROMAT

Cerniere Door Hinges / Charnières de Porte



Apertura 90° / Opening 90° / Ouverture 90°
CROMO / CROMAT



Apertura 180° / 0°-90° / 0°+90°
Opening 180° / 0°-90° / 0°+90°
Ouverture 180° / 0°-90° / 0°+90°
CROMO / CROMAT

Maniglioni Handles / Poignées



SKYLER
INOX LUCIDO
INOX SATINATO

SKYLER - L. 460
SKYLER - L. 660
SKYLER - L. 960
SKYLER - L. 1660



SWAMI
INOX LUCIDO
INOX SATINATO

SWAMI - L. 460
SWAMI - L. 660
SWAMI - L. 960
SWAMI - L. 1660





ART GLASS Porta Vetro

GLASS DOOR
PORTE VITRÉ



ART GLASS
KIA SALFORD*

LINEA SETA
SETA LINE
LIGNE SETA

*
Vetri abbinabili ad ogni finitura
Glasses matching to every finish
Vitres correspondant à chaque finition



ART GLASS
EVA SALFORD*
LINEA SETA / SETA LINE / LIGNE SETA

ART GLASS Porta Vetro

GLASS DOOR
PORTE VITRÉ

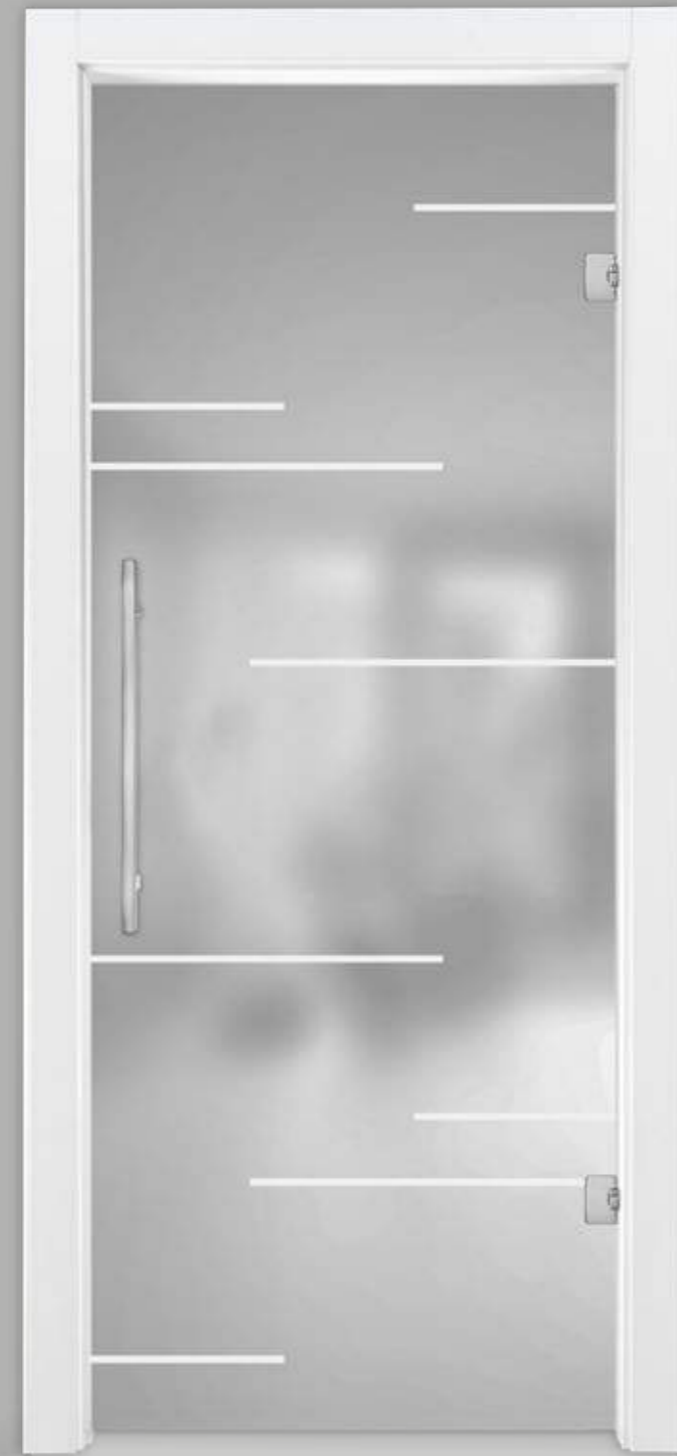

ART GLASS
KIA IKON*

LINEA BIANCA
WHITE LINE
LIGNE BLANC

*
Vetri abbinabili ad ogni finitura
Glasses matching to every finish
Vitres correspondant à chaque finition



ART GLASS
EVA MILOS*
LINEA BIANCA / WHITE LINE / LIGNE BLANC

ART GLASS Porta Vetro

GLASS DOOR
PORTE VITRÉ

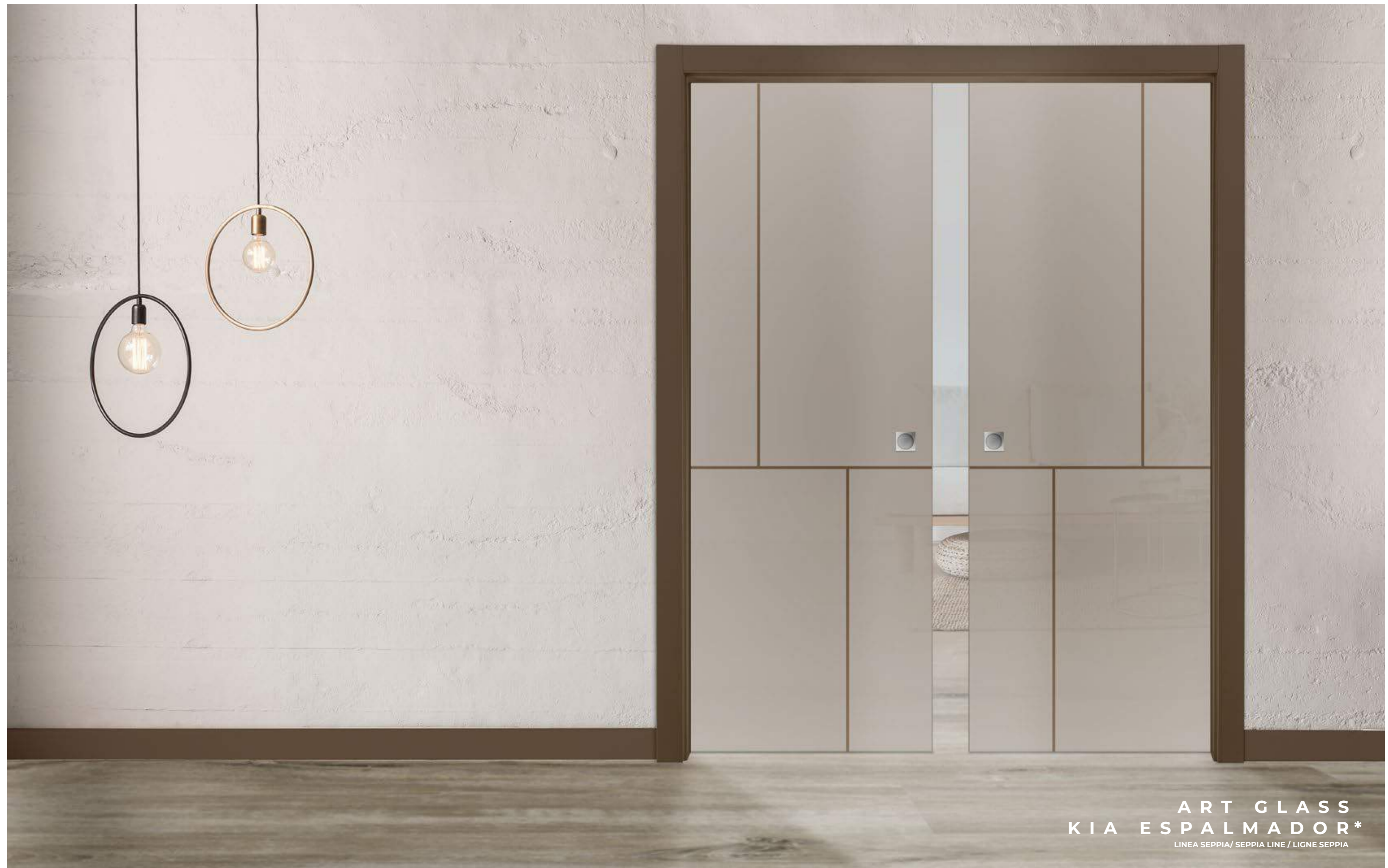

*
Vetri abbinabili ad ogni finitura
Glasses matching to every finish
Vitres correspondant à chaque finition

ART GLASS
KIA ESPALMADOR*
LINEA SEPIA / SEPIA LINE / LIGNE SEPIA

ART GLASS Porta Vetro

GLASS DOOR
PORTE VITRÉ



ART GLASS
KIA ITAPARICA*

LINEA BIANCA
WHITE LINE
LIGNE BLANC

*
Vetri abbinabili ad ogni finitura
Glasses matching to every finish
Vitres correspondant à chaque finition



ART GLASS
KIA FORMENTERA*

LINEA BIANCA/ WHITE LINE / LIGNE BLANC

ART GLASS Porta Vetro

GLASS DOOR
PORTE VITRÉ



ART GLASS
KIA MELVILLE*

LINEA BIANCA
WHITE LINE
LIGNE BLANC

*
Vetri abbinabili ad ogni finitura
Glasses matching to every finish
Vitres correspondant à chaque finition



ART GLASS
KIA TAHAA*

LINEA ARGENTO
SILVER LINE
LIGNE ARGENTÉ



ART GLASS
KIA BORA BORA*
LINEA BIANCA / WHITE LINE / LIGNE BLANC

ART GLASS Porta Vetro

GLASS DOOR
PORTE VITRÉ



**ART GLASS
EVA KAULA***

LINEA BEIGE GRIGIO
BEIGE GRIGIO LINE
LIGNE BEIGE GRIGIO



**ART GLASS
KIA ARGOS***

LINEA BIANCA
WHITE LINE
LIGNE BLANC

*
Vetri abbinabili ad ogni finitura
Glasses matching to every finish
Vitres correspondant à chaque finition



**ART GLASS
KIA LANZAROTE***
LINEA BIANCA / WHITE LINE / LIGNE BLANC

ART GLASS Porta Vetro

GLASS DOOR
PORTE VITRÉ



**ART GLASS
EVA AFIBANA***

LINEA ARGENTO
ARGENTO LINE
LIGNE ARGENTO



**ART GLASS
KIA SENAVAS***

LINEA BIANCA
WHITE LINE
LIGNE BLANC



**ART GLASS
KIA RONHAS***
LINEA BIANCA / WHITE LINE / LIGNE BLANC

*
Vetri abbinabili ad ogni finitura
Glasses matching to every finish
Vitres correspondant à chaque finition

ART GLASS Porta Vetro

GLASS DOOR
PORTE VITRÉ

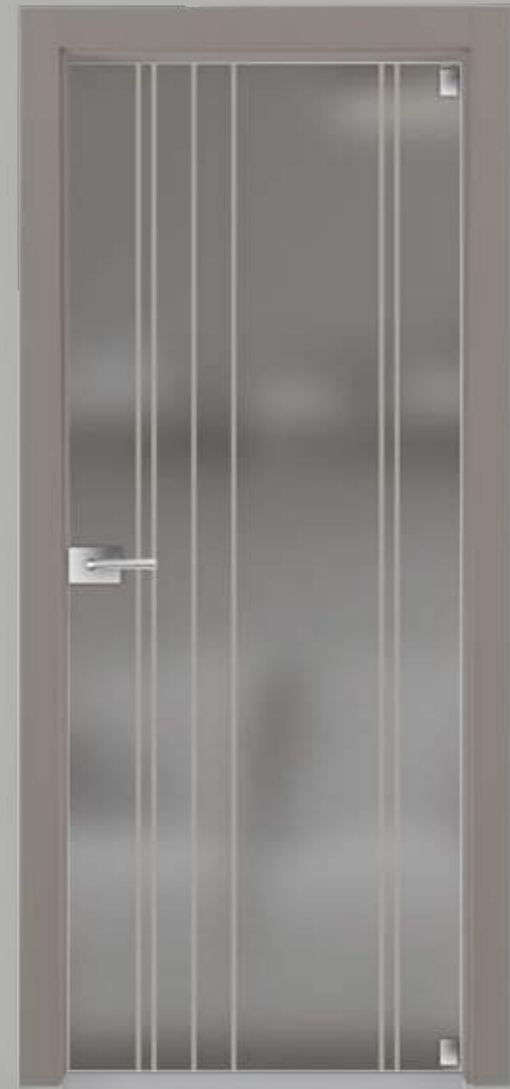

ART GLASS
KIA LYSANDRA*

LINEA GRIGIO BEIGE
GRIGIO BEIGE LINE
LIGNE GRIGIO BEIGE



ART GLASS
KIA RESETA*

LINEA BIANCA
BIANCA LINE
LIGNE BIANCA

*
Vetri abbinabili ad ogni finitura
Glasses matching to every finish
Vitres correspondant à chaque finition



ART GLASS
KIA MEJA*
LINEA NERA / BLACK LINE / LIGNE NERO

ART GLASS Porta Vetro

GLASS DOOR
PORTE VITRÉ



**ART GLASS
KIA COLIBRI***

DISEGNO INDACO
INDACO DRAWING
DESSIN INDACO



**ART GLASS
KIA ROSE***

DISEGNO CARMINIO
CARMINIO DRAWING
DESSIN CARMINIO



**ART GLASS
KIA WATERARUM***
DISEGNO SETA / SETA DRAWING / DESSIN SETA

*
Vetri abbinabili ad ogni finitura
Glasses matching to every finish
Vitres correspondant à chaque finition

Zero-Wall System

ZERO-WALL SYSTEM



ZERO-WALL System

ZERO-WALL SYSTEM
ZERO-WALL SYSTEM

CREA IL TUO SPAZIO

Soluzioni facili per spazi nuovi, i nostri sistemi vengono realizzati con aperture tradizionali o filo muro e sono modulati e personalizzabili per la valorizzazione di piccoli spazi. Zero-Wall presenta tre sistemi studiati appositamente per rispondere a qualsiasi esigenza: Hide, Cloud e Fly

CREATE YOUR SPACE

Easy solutions for new spaces; our systems are made with traditional openings or wall-f lush and feature customizable modules for smaller spaces. Zero-Wall features three design systems to meet any need: Hide, Cloud and Fly

ESPACEZ-VOUS

Des solutions simples pour de nouveaux espaces, nos systèmes sont conçus avec des ouvertures traditionnelles ou encastrées dans le mur et sont modulaires et personnalisables pour mettre en valeur de petits espaces. Zero-Wall présente trois systèmes spécialement conçus pour répondre à tous les besoins : Hide, Cloud et Fly

HIDE

Perfettamente integrato con ogni ambiente, offre un insieme di continuità delle superfici. Realizzabili con differenti sistemi di chiusura, in essenza legnosa, laccato oppure nella variante grezza per una colorazione omogenea delle pareti.

Perfectly integrated with any environment, it offers combined surface continuity. They can be made with different closing systems, in wood, lacquer or unfinished for uniform wall colouring.

Parfaitement intégré à tout environnement, il offre un ensemble de continuité de surface. Réalisable avec différents systèmes de fermeture, en essence de bois, laqué ou en variante brut pour une couleur homogène des murs.



ZERO-WALL System

ZERO-WALL SYSTEM
ZERO-WALL SYSTEM

CLOUD

Ideale per la chiusura di ripostigli, cabine armadio o nicchie, permette di sfruttare al meglio contenitori e vani esistenti di varie tipologie. Realizzabili con differenti sistemi di chiusura, in essenza legnosa e laccato, il tutto per rendere più omogenei gli spazi di un medesimo ambiente integrandoli al meglio con le porte di qualsiasi collezione

Ideal for closing closets, walk-in closets and nooks; it allows you to make the most of existing spaces of various types. They can be made with different closing systems, in wood and lacquer, for more uniform spaces in the same room and the best fit with the doors of any collection

Idéal pour la fermeture de débarras, de placards ou de niches, cela permet de profiter au mieux des conteneurs et des espaces existants de différentes typologies. Réalisables avec différents systèmes de fermeture, en bois massif et laqué, le tout pour rendre les espaces d'un même environnement plus homogènes en les intégrant au mieux avec les portes de n'importe quelle collection



CLOUD

ZERO-WALL System

ZERO-WALL SYSTEM
ZERO-WALL SYSTEM

FLY

Caratterizzato da spessori evidenti, crea volumi unici a parete diventando un elemento decorativo fortemente riconoscibile. Realizzabili con differenti sistemi di chiusura, senza componentistica strutturale a vista, in essenza legnosa e laccato.

Its strong features create unique wall volumes making for highly recognizable decorative elements. Available with different closing systems, without visible structural components, in wood and lacquer.

Caractérisé par des épaisseurs apparentes, il crée des volumes uniques sur le mur, devenant un élément décoratif fortement reconnaissable. Réalisables avec différents systèmes de fermeture, sans composants structurels apparents, en bois massif et laqué



Maniglie, Accessori e Finiture

HANDLES, ACCESSORIES AND FINISHES
POIGNÉES, ACCESSORIES ET FINITIONS



ALATÒ JP 11



Design:
Studio Jean-Philippe Nuel

-  **10** CL Cromo Chrome
-  **10** CM Cromat Matt chrome
-  **30** GL Grafite Graphite
-  **30** GM Grafite Mat Matt graphite

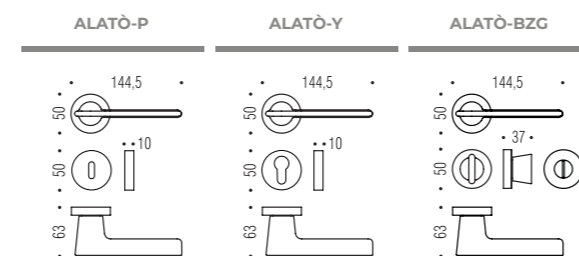

ELLESSE BD 21



Design:
Bartoli Design

-  **10** CL Cromo Chrome
-  **10** CM Cromat Matt chrome
-  **30** GL Grafite Graphite
-  **30** GM Grafite Mat Matt graphite

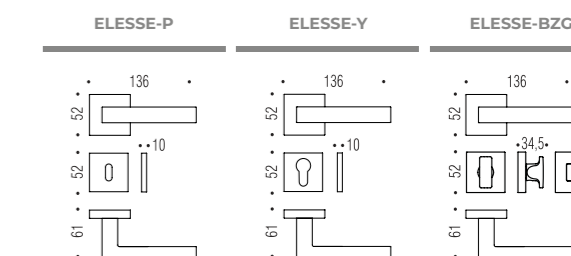

ALATÒ ZERO JP 11



Design:
Studio Jean-Philippe Nuel

-  **10** CL Cromo Chrome
-  **10** CM Cromat Matt chrome
-  **30** GM Grafite Mat Matt graphite

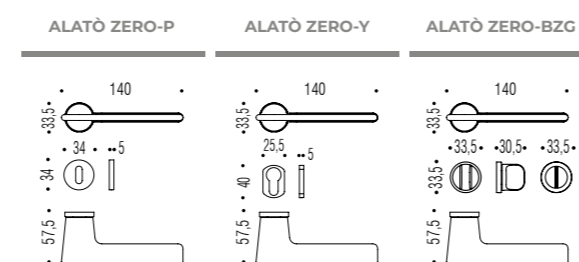

ELLESSE ZERO BD 21



Design:
Bartoli Design

-  **10** CL Cromo Chrome
-  **10** CM Cromat Matt chrome

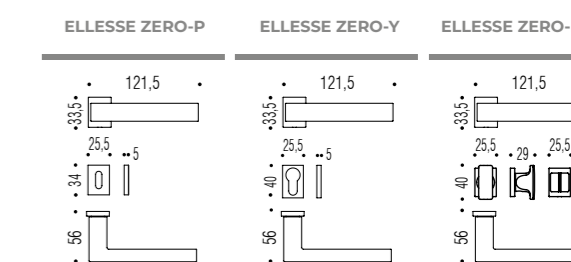

GIRA JM 11



Design:
Jasper Morrison



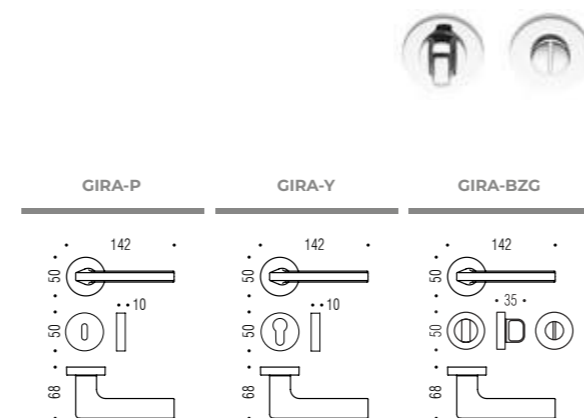

-  **10** CL Cromo Chrome
-  **10** CM Cromat Matt chrome
-  **10** OL Oroplus Oroplus
-  **30** VL Vintage Vintage
-  **30** VM Vintage Mat Matt vintage



ROBOT 4 ID 41



Design:
Colombo Design



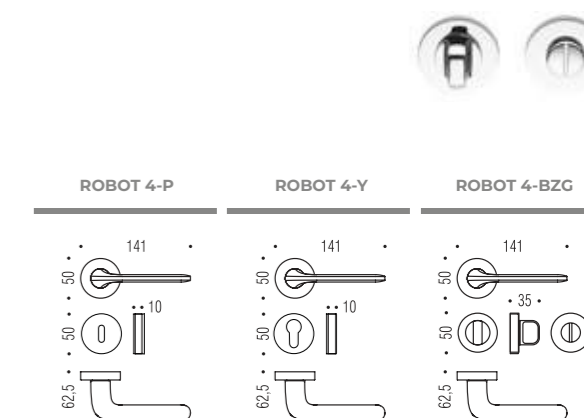

-  **10** CL Cromo Chrome
-  **10** CM Cromat Matt chrome
-  **10** NM ral 9016 Neromat Matt Black
-  **10** BM ral 9005 Biancomat Matt White
-  **10** OL Oroplus Oroplus
-  **30** OM Oromat Matt gold



GIRA ZERO JM 11



Design:
Jasper Morrison



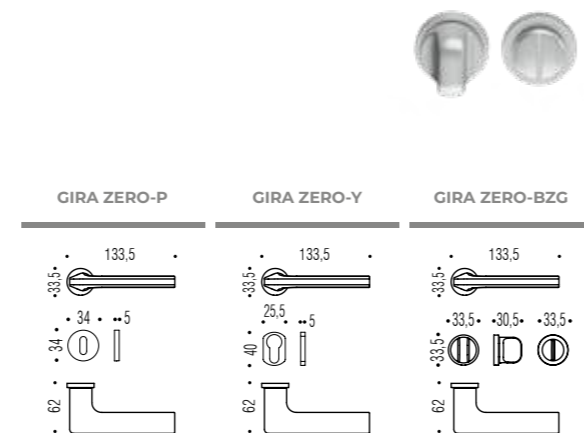

-  **10** CL Cromo Chrome
-  **10** CM Cromat Matt chrome
-  **10** OL Oroplus Oroplus
-  **30** VM Vintage Mat Matt vintage



ROBOT 4 ZERO ID 41



Design:
Colombo Design

-  **10** CL Cromo Chrome
-  **10** CM Cromat Matt chrome
-  **10** OL Oroplus Oroplus
-  **30** OM Oromat Matt gold

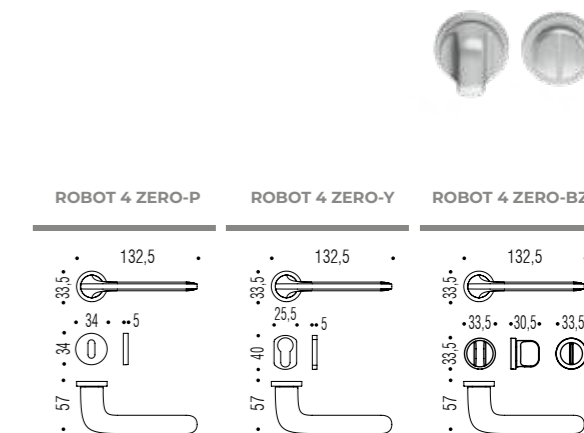

ROBOT 4S ID 51



COLOMBO

Design:
Colombo Design

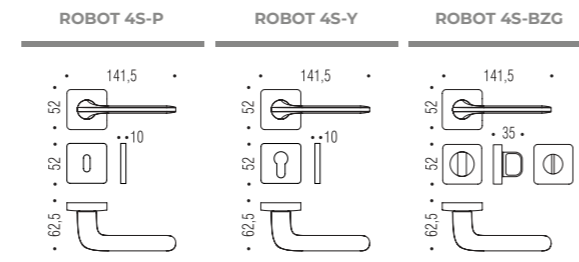

ROBOT 4S ZERO ID 51



COLOMBO

Design:
Colombo Design

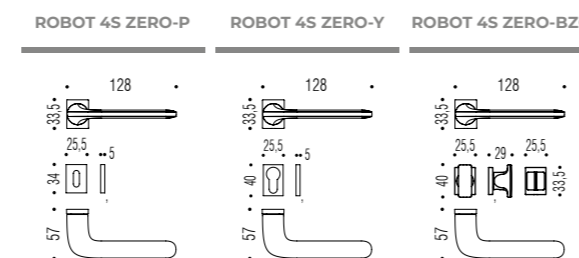

ROBOT 5 ID 61



COLOMBO

Design:
Colombo Design

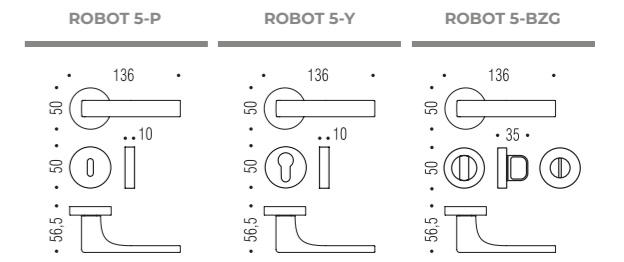
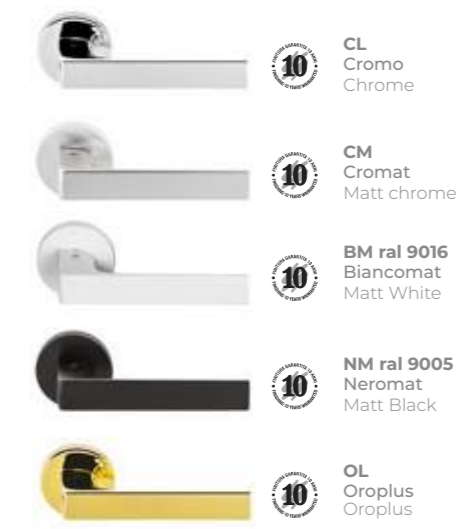

ROBOT 5 ZERO ID 61



COLOMBO

Design:
Colombo Design

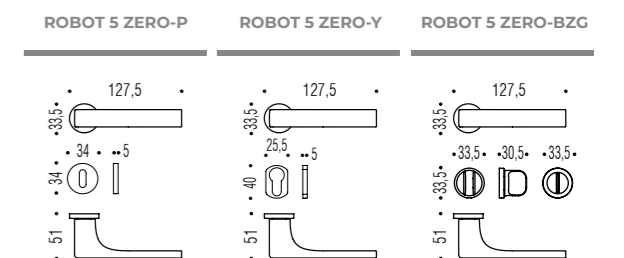





ROBOT 5S ID 71



COLOMBO

Design:
Colombo Design

-  **10** CL Cromo Chrome
-  **10** CM Cromat Matt chrome
-  **30** GL Grafite Graphite
-  **30** GM Grafite Mat Matt graphite
-  **10** NM ral 9005 Neromat Matt Black
-  **10** BM ral 9016 Biancomat Matt White

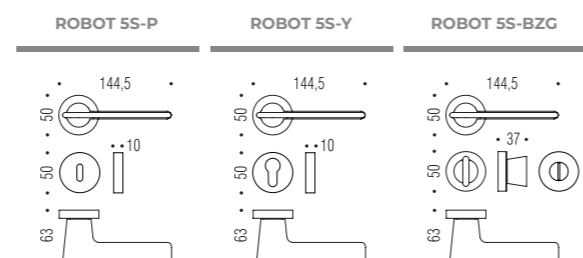

COLOMBO

TOOL MD11



COLOMBO

Design:
Michele De Lucchi

-  **10** CL Cromo Chrome
-  **10** CM Cromat Matt chrome

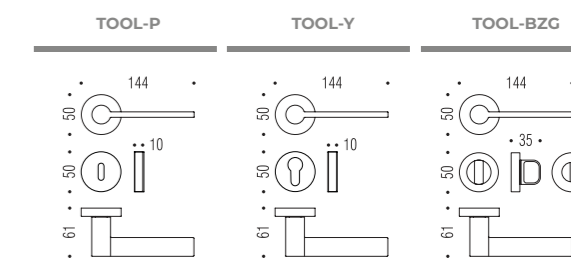





ROBOT 5S ZERO ID 71



COLOMBO

Design:
Colombo Design

-  **10** CL Cromo Chrome
-  **10** CM Cromat Matt chrome
-  **30** GM Grafite Mat Matt graphite
-  **10** NM ral 9005 Neromat Matt Black
-  **10** BM ral 9016 Biancomat Matt White

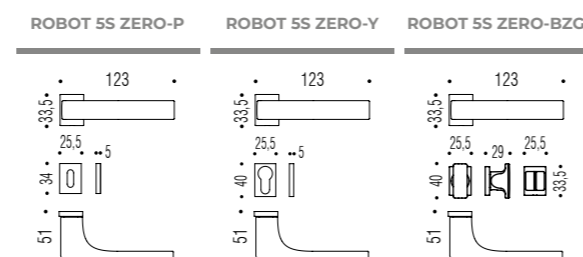



COLOMBO

TOOL ZERO MD11



COLOMBO

Design:
Michele De Lucchi

-  **10** CL Cromo Chrome
-  **10** CM Cromat Matt chrome

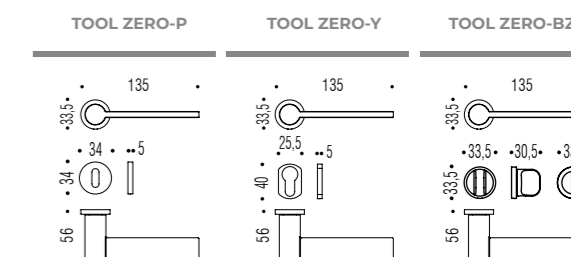

ZELDA MM11



Design:
Jean Marie Massaud



10 CL
Cromo
Chrome



10 CM
Cromat
Matt chrome

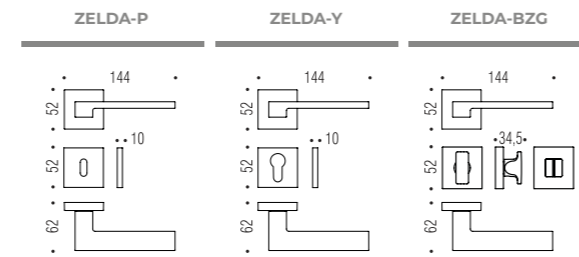

ELECTRA MS 11



Design:
Messineo e Settinelli



10 CM
Cromat
Matt chrome



10 NM ral 9005
Neromat
Matt Black



30 VM
Vintage Mat
Matt vintage

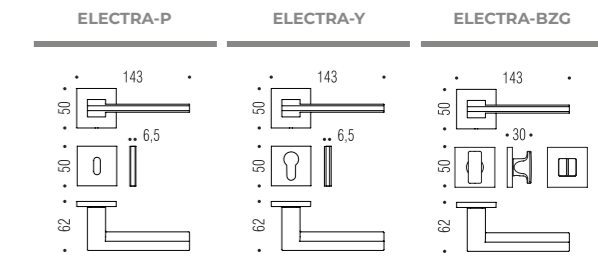

ZELDA ZERO MM11



Design:
Jean Marie Massaud



10 CL
Cromo
Chrome



10 CM
Cromat
Matt chrome

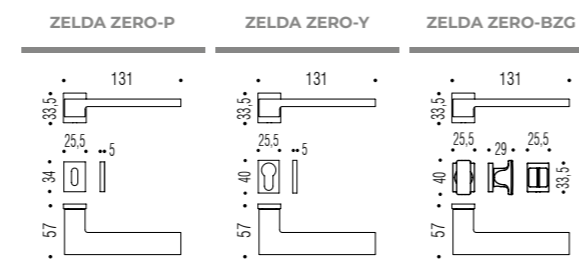

963 ML 11 RSB

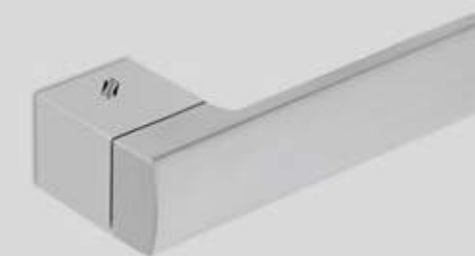

Design:
Mik&luke



10 CM
Cromat
Matt chrome



30 GM
Grafite Mat
Matt graphite

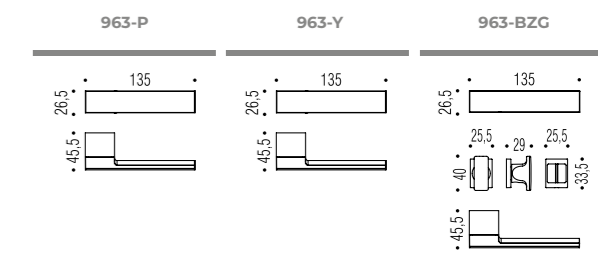

FEDRA AC T1



COLOMBO

Design:
Andrea Castrignano

-  **10** CL Cromo Chrome
-  **10** CM Cromat Matt chrome
-  **10** NM ral 9005 Nero Mat Matt Black
-  **10** OL Oroplus Oroplus
-  **30** VL Vintage Vintage
-  **30** VM Vintage Mat Matt vintage

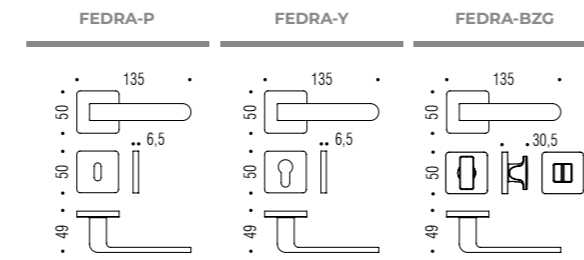

SQUARE LC25



COLOMBO

Design:
Colombo Design

-  **10** CL Cromo Chrome
-  **10** CM Cromat Matt chrome
-  **30** GM Grafite Mat Matt Graphite
-  **30** VL Vintage Vintage
-  **30** VM Vintage Mat Matt vintage

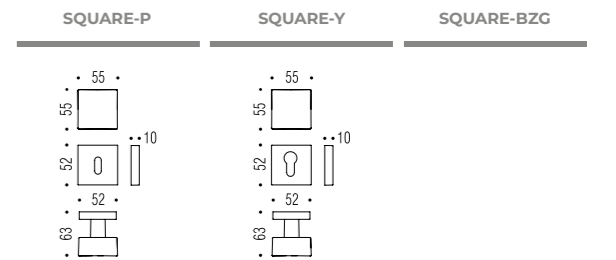

PEAK PJ T1



COLOMBO

Design:
Patrick Jouin

-  **10** CL Cromo Chrome
-  **10** CM Cromat Matt chrome
-  **30** GM Grafite Mat Matt graphite
-  **10** NM ral 9005 Nero Mat Matt Black
-  **10** OM Oromat Matt gold
-  **30** VM Vintage Mat Matt vintage

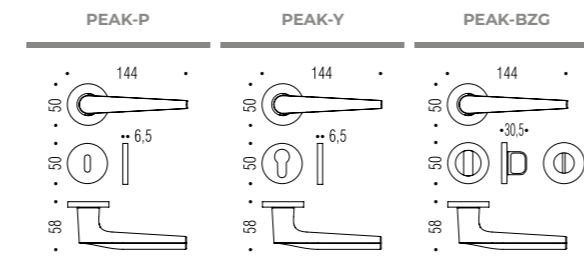

ROBOT CD45



COLOMBO

Design:
Colombo Design

-  **10** CL Cromo Chrome
-  **10** CM Cromat Matt chrome
-  **10** OL Oroplus Oroplus
-  **30** OM Oromat Matt gold
-  **BR** BRonzo Bronze
-  **10** NM ral 9005 Neromat Matt Black

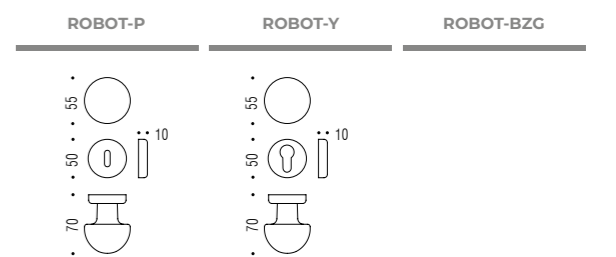

MOOD ONE CC11



Design:
Colombo Design

AGO mood
COLLECTION



10 Sabbia
AGO



10 Terra
AGO

mood
COLLECTION



10 Lime Green



10 Lemon Yellow



10 Sunset Orange



10 Strawberry Red



10 Claret Violet



10 Black



10 White



10 Ocean Blue



10 Capri Blue

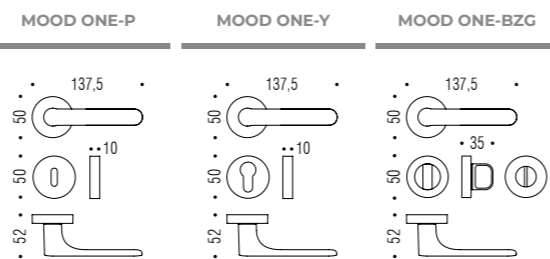

MOOD ONEQ CC21



Design:
Colombo Design

AGO mood
COLLECTION



10 Sabbia
AGO



10 Terra
AGO

mood
COLLECTION



10 Lime Green



10 Lemon Yellow



10 Sunset Orange



10 Strawberry Red



10 Claret Violet



10 Black



10 White



10 Ocean Blue



10 Capri Blue

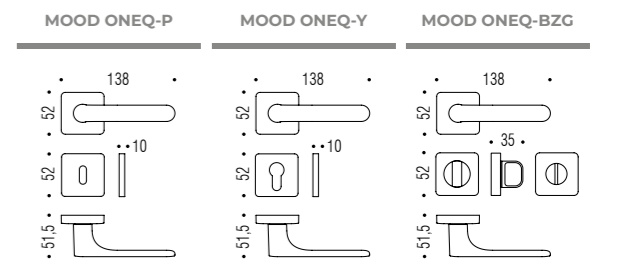

ARTIC

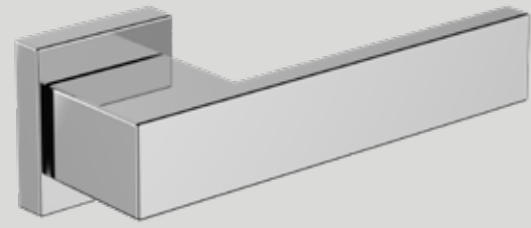

CL
Cromo
Chrome



CM
Cromat
Matt chrome



BM ral 9016
Bianco
Matt White



NM ral 9005
Neromat
Matt Black

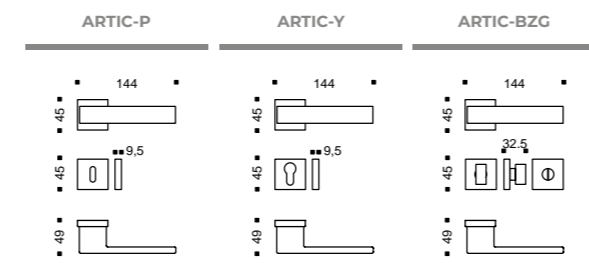

ATLANTIC

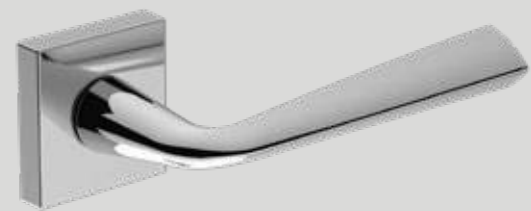

CL
Cromo
Chrome



CM
Cromat
Matt chrome

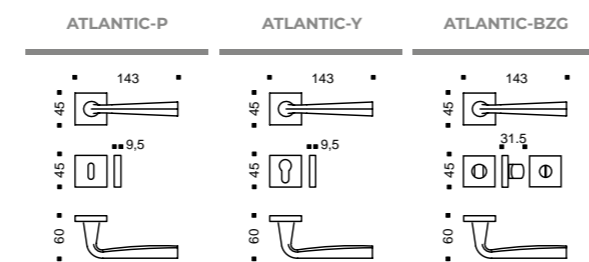

BALTIC



CL
Cromo
Chrome



CM
Cromat
Matt chrome

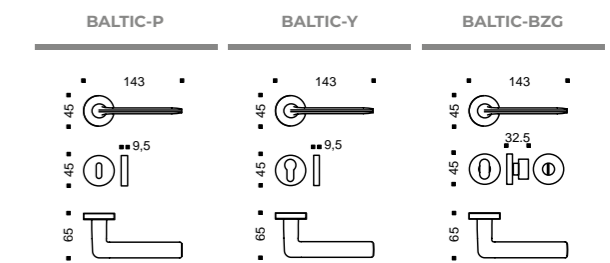

BARENTS

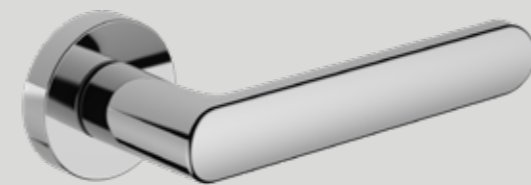

CL
Cromo
Chrome



CM
Cromat
Matt chrome



BM ral 9016
Bianco
Matt White



NM ral 9005
Neromat
Matt Black



OL
Oroplus
Oroplus



OM
Oromat
Matt gold

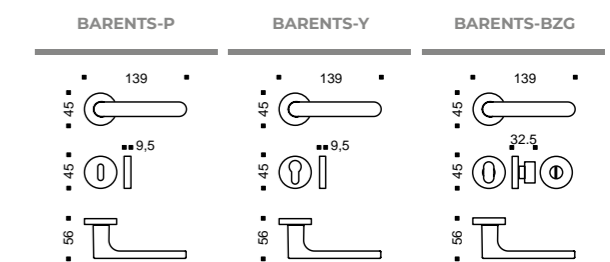

CARRIBEAN



CL
Cromo
Chrome



CM
Cromat
Matt chrome



BM ral 9016
Bianco
Matt White



NM ral 9005
Neromat
Matt Black



OL
Oro lucido
Gold



OM
Oromat
Matt gold

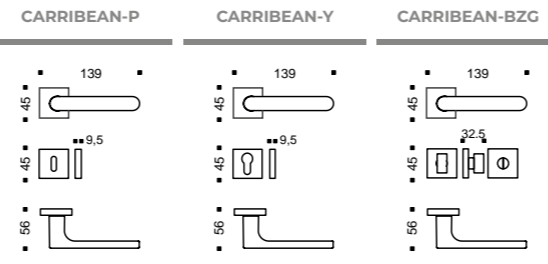

EAGLE

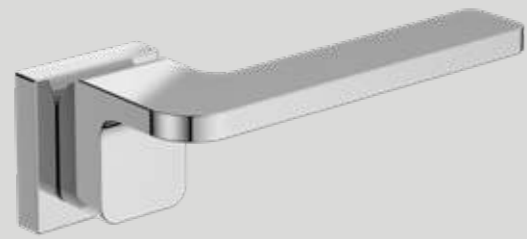

CL
Cromo
Chrome



CM
Cromat
Matt chrome



NM ral 9005
Neromat
Matt Black



BR
Bronzo
Bronze

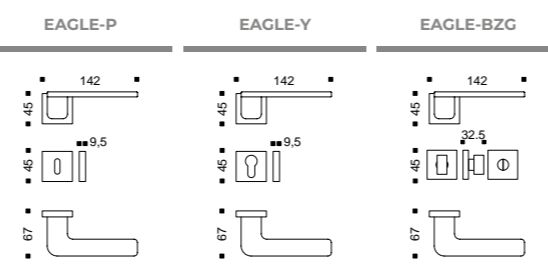

GRACE

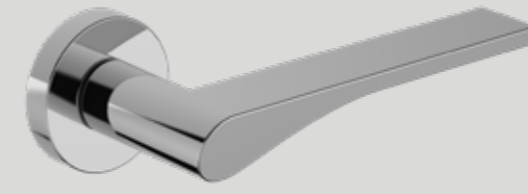

CL
Cromo
Chrome



CM
Cromat
Matt chrome



NM ral 9005
Neromat
Matt Black



BR
Bronzo
Bronze

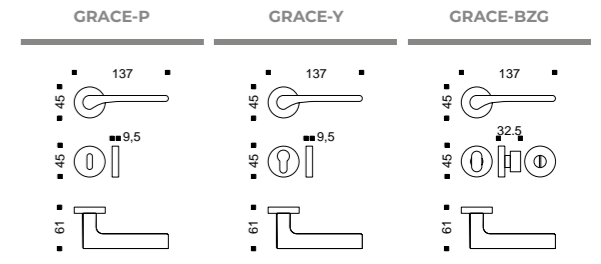

ILLETES

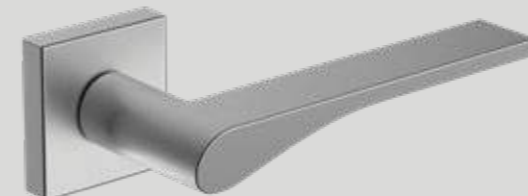

CL
Cromo
Chrome



CM
Cromat
Matt chrome



NM ral 9005
Neromat
Matt Black



BR
Bronzo
Bronze

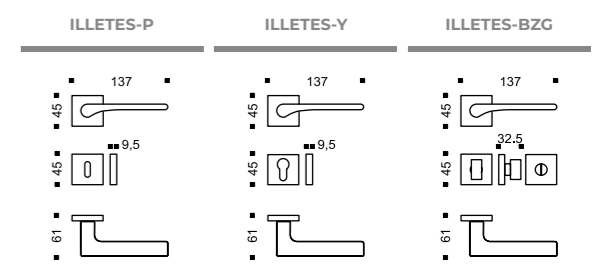

INDIAN

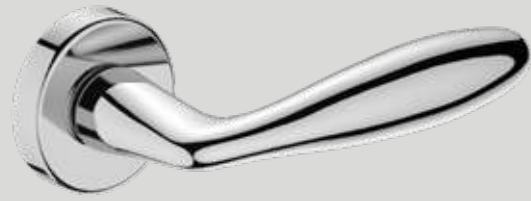

CL
Cromo
Chrome



CM
Cromat
Matt chrome



BR
Bronzo
Bronze



OL
Oro lucido
Gold

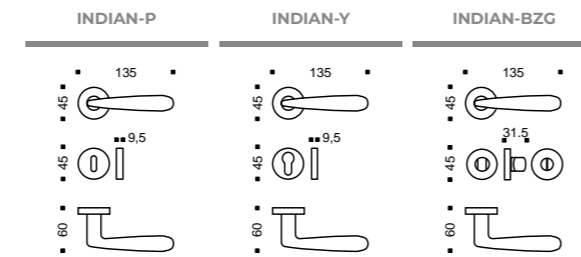

MAGENS

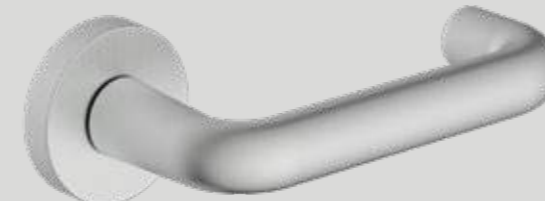

CL
Cromo
Chrome



CM
Cromat
Matt chrome



NM ral 9005
Neromat
Matt Black



BR
Bronzo
Bronze



OL
Oro lucido
Gold

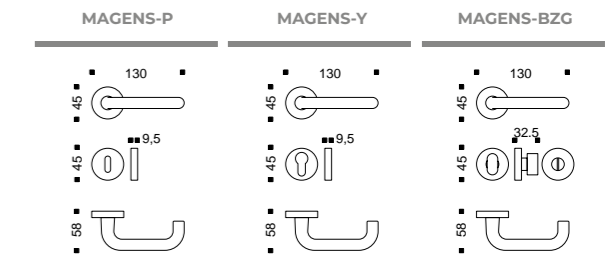

IONIAN



CL
Cromo
Chrome



CM
Cromat
Matt chrome

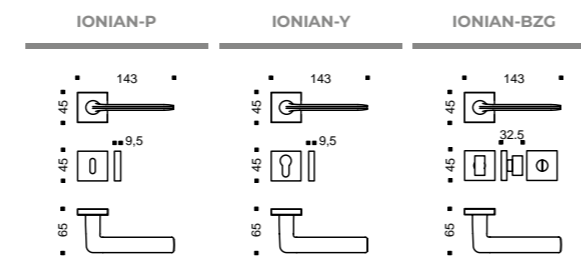

MATIRA



CL
Cromo
Chrome



CM
Cromat
Matt chro-



NM ral 9005
Neromat
Matt Black



BR
Bronzo
Bronze

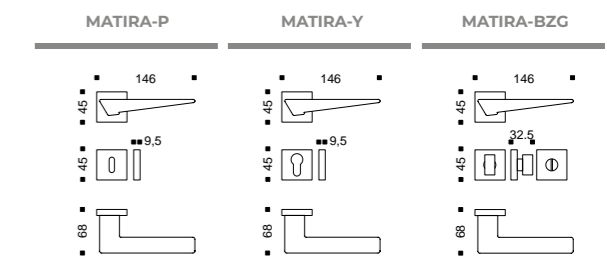

MEDITERRANEAN

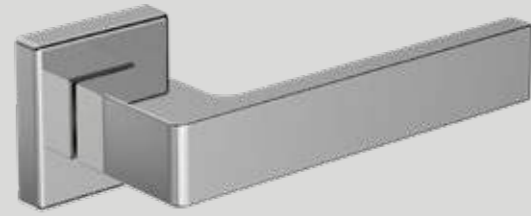

CL
Cromo
Chrome



CM
Cromat
Matt chrome



BM ral 9016
Bianco
Matt White



NM ral 9005
Neromat
Matt Black



MEDITERRANEAN-P MEDITERRANEAN-Y MEDITERRANEAN-BZG

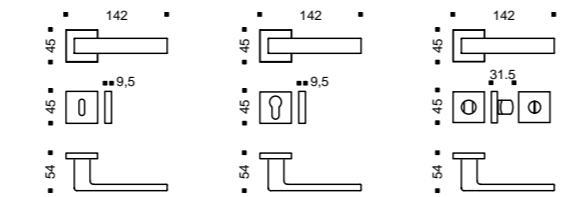

PARAISO



CL
Cromo
Chrome



CM
Cromat
Matt chrome



OL
Oro lucido
Gold



PARAISO-P PARAISO-Y PARAISO-BZG

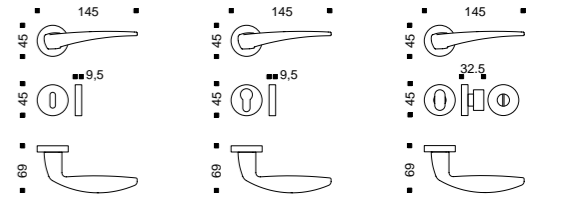

PACIFIC

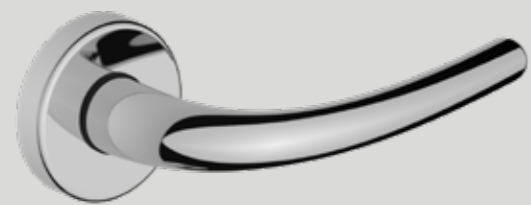

CL
Cromo
Chrome



CM
Cromat
Matt chrome



BR
Bronzo
Bronze



OL
Oro lucido
Gold



PACIFIC-P PACIFIC-Y PACIFIC-BZG

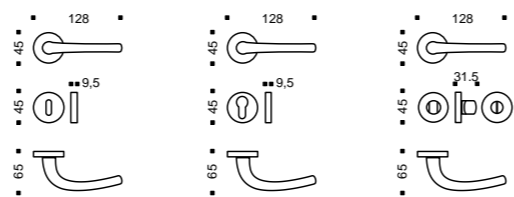

RIANA



CL
Cromo
Chrome



CM
Cromat
Matt chrome



BM ral 9016
Bianco
Matt White



NM ral 9005
Neromat
Matt Black



RIANA-P RIANA-Y RIANA-BZG

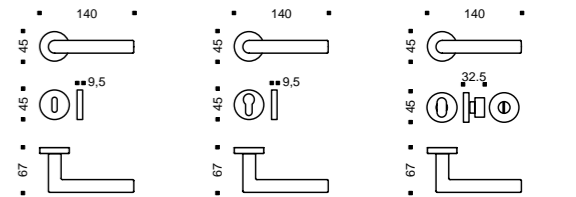

BOCA



CL
Cromo
Chrome

CM
Cromat
Matt chrome

NM ral 9005
Neromat
Matt Black

BR
Bronzo
Bronze

OL
Oro lucido
Gold

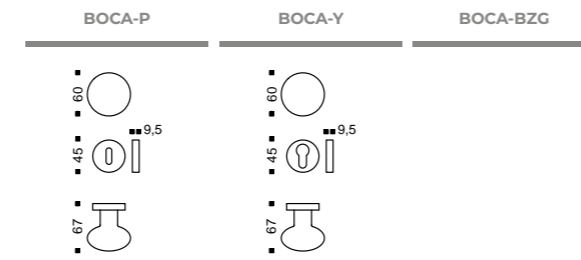

RECTA



CM
Cromat
Matt chrome

BM ral 9016
Bianco
Matt White

NM ral 9005
Neromat
Matt Black

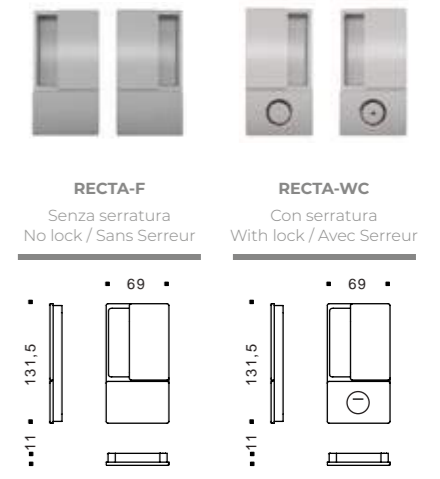

OFU



CL
Cromo
Chrome

CM
Cromat
Matt chrome

NM ral 9005
Neromat
Matt Black

BR
Bronzo
Bronze

OL
Oro lucido
Gold

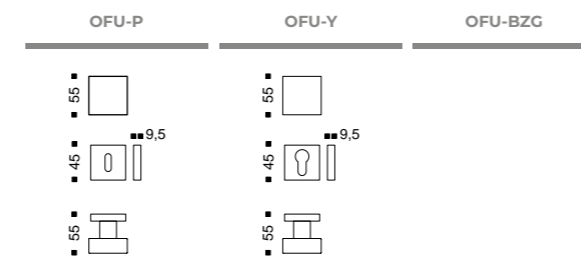

DUG



Maniglia di presa integrata / Integrated grip handle / Poignée de préhension intégrée

DUG-200

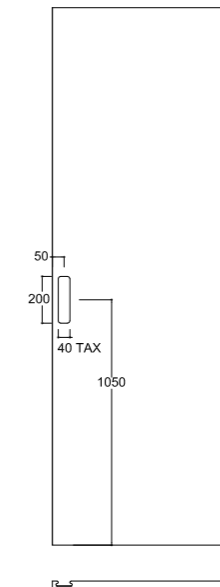

DUG-1300

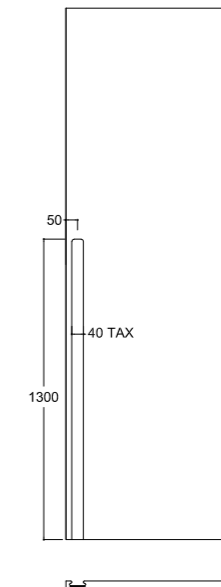

DUG-200 E DUG-1300
DISPONIBILI SOLO PER
LACCATI (in medesima
finitura della laccatura)
e LEGNI (in finitura MDF
nero)
AVAILABLE ONLY FOR
LACQUERED (same finish as
lacquer) and WOOD
(in black MDF finish)

DISPONIBILE UNIQUEMENT
POUR LAQUÉ (même
finition que la laque) et BOIS
(en finition MDF noire)

DUG-200 E DUG-1300
Applicabile unicamente
a sistema FERMO
MAGNETICO
(senza blocco)
Applicable only to system
MAGNETIC LOCK
(without locking)

Applicable uniquement
au système
VERROUILLAGE
MAGNÉTIQUE (sans
blocage)

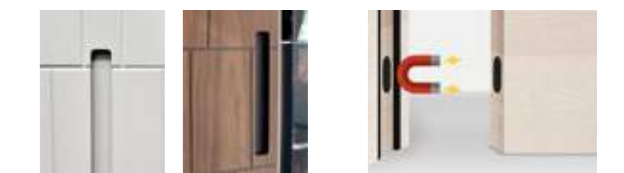

Ferramenta

HARDWARE
FERRAGE

Cover

Guarnitura per cardine porta BASIC (opzionale)
Cover for BASIC hinge (optional)
Cache-gonds pour charnières système BASIC (optionnel)



Pomellino a scatto

Snap knob/ Bouton d'accrochage



Sistemi pushpull

Pushpull system/ Loose unmounted accessories



Fermi magnetici

Magnetic stops/ Butées magnétiques



Ferramenta

HARDWARE
FERRAGE

Serrature / Locks / Serrures

Solo per porte a Battente
Only for Swing doors
Uniquement pour les portes à Bate



Solo per porte scorrevole PASSING
Only for Sliding doors PASSING
Uniquement pour les portes coulissantes PASSING



Cerniere Invisibili / Invisible Hinge / Charnière Invisibles

Solo per versioni PLANYA, GHOST e LEVEL
Only for PLANYA, GHOST and LEVEL version
Uniquement pour versions PLANYA, GHOST et LEVEL



Conchiglie per Porte Scorrevoli

Flush Door-handl / Poignée de Porte Coulissant



Laccati

LACQUERED / LAQUEÉS

Finiture / Finishings / Finitions

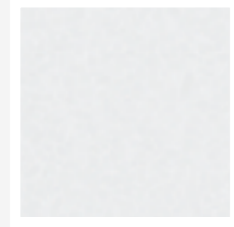

TOUCH
Finitura liscia Standard
Smooth Standard finishing
Finition lisse standard



VELVET
Finitura gofrata a richiesta
Embossed finish on request
Finition gaufrée sur demande

Base Colours

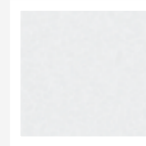

BIANCO 03

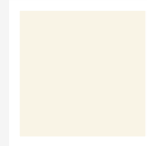

CREMA 01

Standard Colours

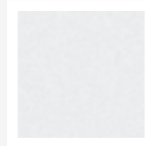

BIANCO
RAL 9016

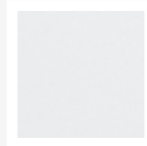

BIANCO
RAL 9010



GRIGIO TEL4
RAL 7047

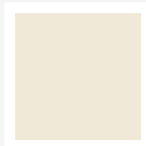

AVORIO
RAL 1013



OCRA
NCS S 3005 Y 20R

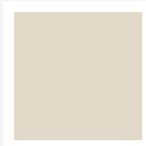

BEIGE SABBIA
NCS S 1505 Y 50R



GRIGIO ROSSO
NCS S 2005 Y 50R



GRIGIO SETA
RAL 7044



BEIGE CRIGIO
RAL 1019



GRIGIO BEIGE
RAL 7006



MARRONE PALLIDO
RAL 8025

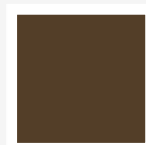

MARRONE
SEPIA
RAL 8014

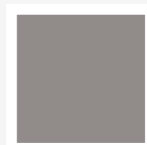

GRIGIO
TORTORA
NCS S 5000 N

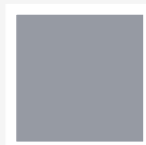

GRIGIO
ARGENTO
RAL 7001



GRIGIO
ARDESIA
RAL 7015



NERO
TRAFFICO
RAL 9017



ECRÙ

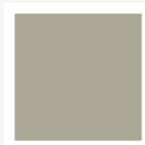

TORTORA

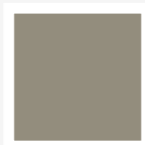

LAND



LONDRA



DAKAR



SALVIA

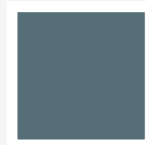

BALENA

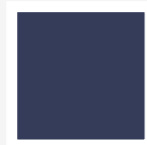

BLURMANI



ROSSO
TRAFFICO
RAL 3020



ARANCIO
PURO
RAL 2004



VERDE
GIALLO
RAL 6018



VIOLETTO
PASTELLO
RAL 4009

RAL Colours

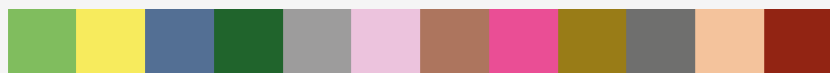

Esclusi colori RAL speciali a richiesta / Excluding special RAL colours on request /
Hors couleurs spéciales RAL sur demande: RAL 1026-1035-1036-2005-2007-2013-3024-3026-3032-
3033-4011-4012-5025-5026-6035-6038-7048-8029-9022-9023

Texture

TEXTURE / TEXTURE

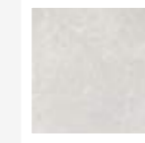

CONCRETE



CEMENT



BIANCO

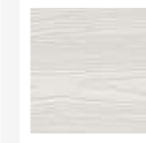

FRASSINO
BIANCO



POROAPERTO
BIANCO

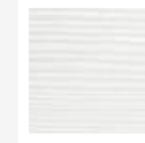

SPAZZOLATO
BIANCO

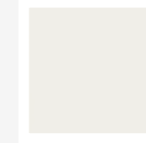

AVORIO

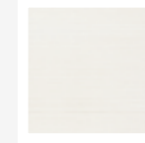

SPAZZOLATO
AVORIO



MATRIX

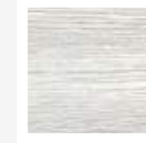

ROVERE
COUNTRY

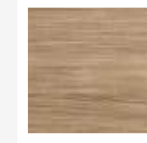

ROVERE
AMBIENT

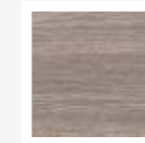

ROVERE
CENERE

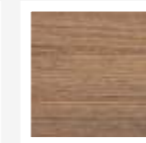

ROVERE
FIAMMA

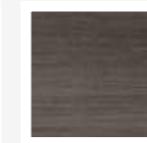

ROVERE
FUOCO

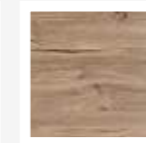

BIOVINTAGE

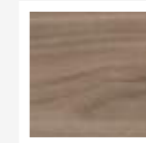

WALNUT
USA

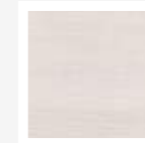

ROVERE
SAHARA

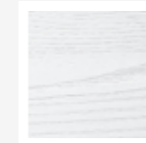

ROVERE
ARTICO

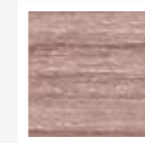

NOCE
CLEAR

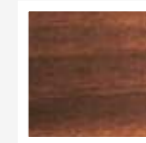

NOCE
NAZIONALE

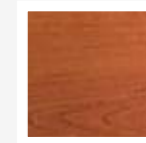

CILIEGIO

Legni

WOOD / BOIS

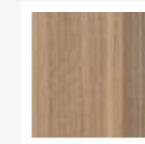

CANALETTO
NATURALE TOUCH

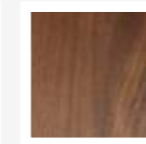

CANALETTO
LIGHT TOUCH

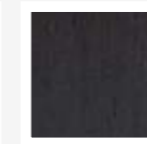

CANALETTO
ARDESIA TOUCH

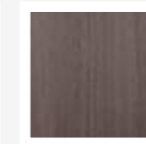

CANALETTO
COOL TOUCH

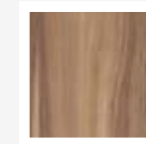

NOCE NAZIONALE
NATURALE TOUCH

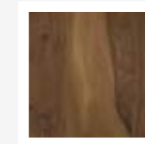

NOCE NAZIONALE
LIGHT TOUCH

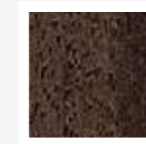

NOCE NAZIONALE
CARBON TOUCH

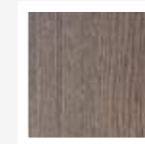

FRASSINO
COOL TOUCH

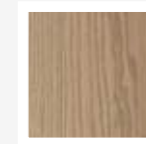

FRASSINO
GLAM TOUCH

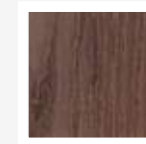

FRASSINO
THERMO TOUCH

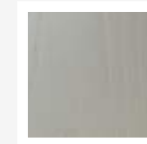

FRASSINO
PORO LACCATO

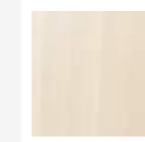

TANGANIKI
VANIGLIA TOUCH

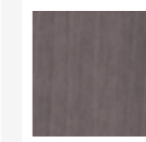

TANGANIKI
COOL TOUCH

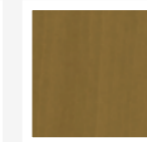

TANGANIKI
GLAM TOUCH

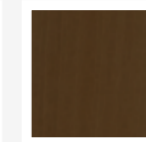

TANGANIKI
THERMO TOUCH

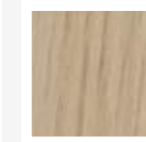

ROVERE
NATURALE TOUCH



ROVERE
LIGHT TOUCH

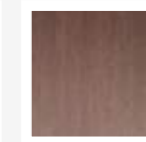

ROVERE
THERMO TOUCH

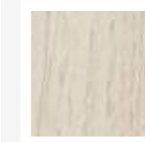

ROVERE
VANIGLIA TOUCH

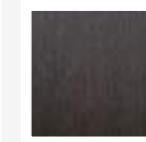

ROVERE
CARBON TOUCH

AGOPROFIL S.p.a.

Regione Rossi N°1 12060
Belvedere Langhe (CN) Italia

CONTATTI:

TEL: (+39) 0173.74.30.03
FAX: (+39) 0173.79.70.39

info@agoprofil.com
www.agoprofil.com



*Per l'oggettiva impossibilita' di riprodurre fedelmente in stampa le variegata tonalita' del legno e delle laccature delle nostre produzioni, le immagini dei cataloghi non sono vincolanti ai fini delle forniture.

*Wood and lacquers shades reproductions in print don't represent realistically the live colors and the whole variety of our products, thus the images in the catalogues are not binding for the purposes of sale.

*Репродукции оттенков дерева и лаков в печатных изданиях не передают реалистично живые цвета и все разнообразие нашей продукции, поэтому изображения в каталогах не являются обязывающими для целей продажи.

AGOPROFIL[®]
P O R T E  P E N S A T E

Info@agoprofil.com
www.agoprofil.com